

Quick Installation Guide

Printer Components:

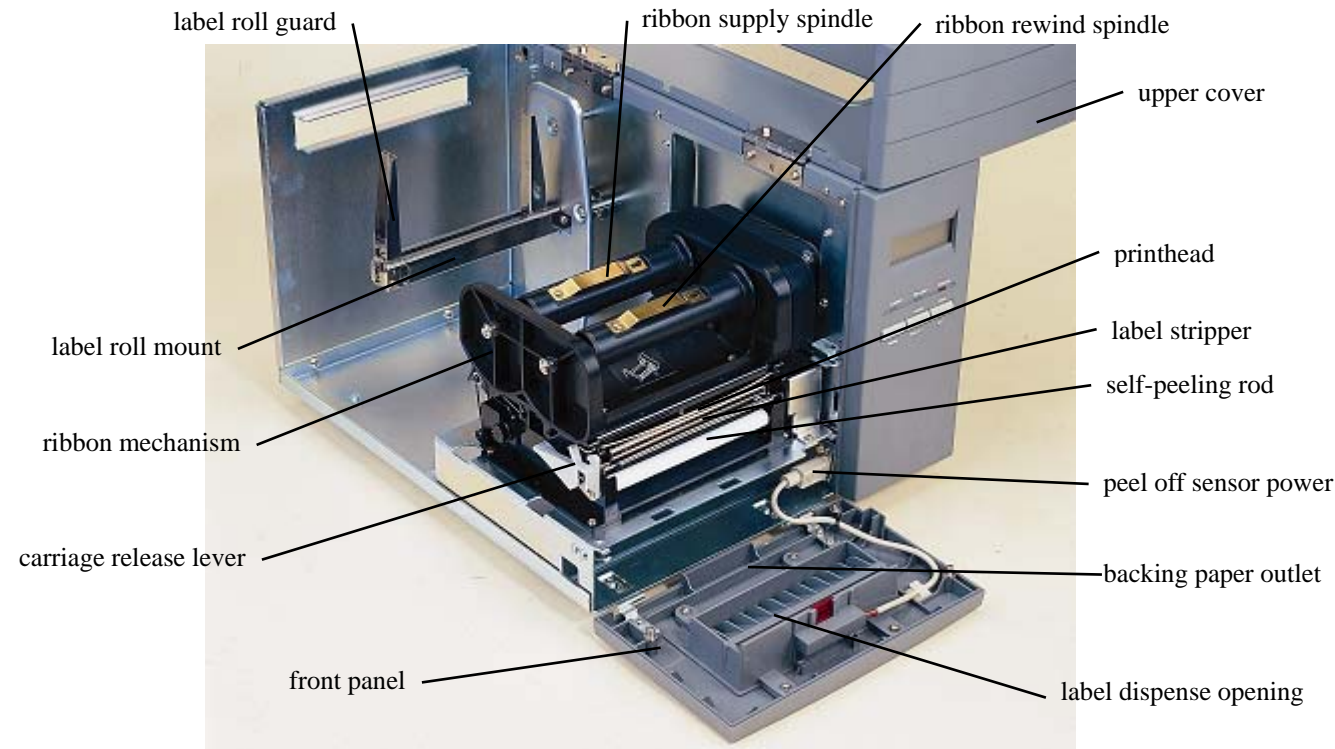

A: Hardware Installation:

1. Connect the printer to the computer with the provided printer cable.
2. Plug one end of the power cord into the power connector at the rear of the printer, and then plug the other end into a properly grounded wall outlet.
3. Open the printer cover and install the ribbon
 - i. Place an empty paper core onto the ribbon rewind spindle. (It is to be noticed that in the absence of an empty paper core, error may occur when the printer is in operation.)
 - ii. Install ribbon on the ribbon supply spindle in the direction so that the ribbon routes as described in step iv.
 - iii. Disengage the printer carriage by pulling the carriage release lever upwards.
 - iv. Following the direction of the **↓ RIBBON** label, pull the transparent ribbon leader to the front from under the ribbon mechanism. Attach the ribbon leader to the empty paper core on the ribbon rewind spindle (with a tape)
 - v. Manually rotate the the ribbon rewind spindle until the ribbon overlaps the ribbon leader and stretches tight.
 - vi. Engage the printer carriage.



4. Open the printer cover and install the label roll
 - i. Lower the label roll guard to the horizontal position, slide the label roll into onto the (external) label roll mount, and then flip back the label roll guard.
 - ii. Disengage the printer carriage by pulling the carriage release lever upwards.
 - iii. Install the label so that it goes (when using an external label roll mount: through the label feed slot) in the direction of the **↓ LABEL** label and under the ribbon mechanism to lay upon the platen.
 - iv. To use the self-peeling function, tear off the first few labels, turn the carriage release lever backwards, guide the backing paper over the (metal) label stripper and then downwards insert it between the platen and the self-peeling rod.
 - v. Adjust the label guide to fit the width of the label.
 - vi. (Manually) Rotate the label roll until it is stretched tight.
 - vii. Engage the printer carriage.

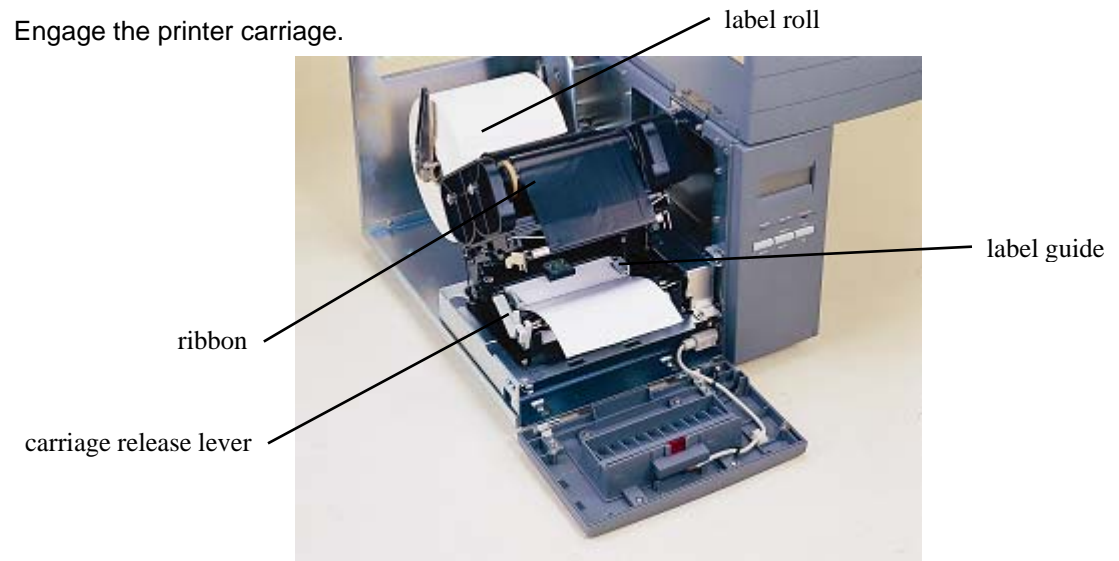

5. Close the printer cover.
6. Switch on the printer. Press the **FEED** button a few times until the **ON-LINE** indicator illuminates, and the printer is ready to print.

Note: When switched on, the printer will automatically detect whether ribbon is installed to judge whether the printer is in thermal direct or thermal transfer mode. As such, to use thermal transfer mode, be sure to install the ribbon, the label, and engage the ribbon mechanism before you switch on the printer. To use thermal direct mode, install the label and engage the ribbon mechanism before switching on the printer.

When the printer is out of ribbon or label, the ON-LINE LED will not come on and the ERROR LED will flash. Reload the ribbon or media without turning off the printer. Press the FEED button a few times until the ON-LINE LED illuminates, the printing job will be resumed without data loss.

B: Power-On Utilities

■ Self Test

Install the label first. Press the **FEED** button and then turn on the printer. Do not release the **FEED** button until the printer feeds labels. The printer performs the following items:

1. Calibrate label pitch
2. Print out thermal print head check pattern
3. Print the internal settings
4. Enter into dump mode

■ Gap Sensor Calibration

This utility is used to calibrate the sensitivity of the gap sensor. Users may have to calibrate the gap sensor on two occasions:

1. Changing to a new type of label
2. Initializing the printer

Note: The ERROR LED may flash if the gap sensor is not calibrated properly.

Please follow the steps below to calibrate the gap sensor.

1. Turn off printer power and install blank (i.e., without any logos or characters) label roll on the printer.
2. Hold down the **PAUSE** button while turning on printer power.
3. Release **PAUSE** button when the printer feeds label. Do not turn off printer until the printer stops and the two green LEDs light on.

■ Printer Initialization

Printer initialization clears all downloaded files resident in flash memory, sets printer parameters to default values.

Please follow the steps below to initialize the printer:

1. Turn off the printer power.
2. Hold down the **PAUSE** and **FEED** buttons while turning on the printer power.
3. Do not release the buttons until the three LEDs flash in turn.

Note: When printer initialization is done, please calibrate the gap sensor again.

For further information on printer operation, please refer to the user's manual in Driver CD disc.