

***TTP-244ME Plus / 342M Plus***

**THERMAL TRANSFER / DIRECT THERMAL BAR  
CODE PRINTER**

**USER'S  
MANUAL**

# CONTENTS

<b>1. PRODUCT INTRODUCTION .....</b>	<b>1</b>
1.1 Compliances.....	1
<b>2. GETTING STARTED.....</b>	<b>3</b>
2.1 Unpacking and Inspection.....	3
2.2 Equipment Checklist .....	3
2.3 Printer Parts .....	4
2.4 Buttons and Indicators .....	7
<b>3. SET UP.....</b>	<b>9</b>
3.1 Setting Up the Printer.....	9
3.2 Loading Label Stock.....	9
3.3 Self-Peeling Function.....	12
3.4 Cutter Function.....	14
3.5 Ribbon Loading Instructions .....	15
3.6 Self Test.....	18
3.7 Dump Mode.....	20
<b>4. USING THE PRINTER .....</b>	<b>21</b>
4.1 Power-on Utilities .....	21
4.1.1 Self Test Utility .....	21
4.1.2 Gap Sensor Calibration Utility.....	21
4.1.3 Printer Initialization .....	22
4.2 Troubleshooting Guide.....	23
<b>APPENDIX A MENU CONTROL FLOWCHART .....</b>	<b>1</b>

# 1. PRODUCT INTRODUCTION

Thank you very much for purchasing this bar code printer. The attractive printer delivers superior performance at an economical price. Both powerful and easy-to-use, this printer is your best choice.

The printer offers both thermal transfer and direct thermal printing at user selectable speeds: either 1.5, 2.0, 3.0 and 4.0 IPS (Inch Per Second) for 203 DPI model; 1.0, 1.5 and 2.0 IPS for 300 DPI model. It can accept a wide range of media, including roll feed, die-cut, and fan-fold labels for both thermal transfer and direct thermal printing. All of the most frequently used bar code formats are available. Fonts and bar codes can be printed in any one of the four directions. This printer provides a choice of five different sizes of alphanumeric fonts. By using font multiplication, an even greater range of sizes is possible. Smooth fonts can be down-loaded from the user friendly, Windows labeling software. In addition, this printer is capable of independently executing BASIC programming functions, including arithmetic, logical operation, loop, flow-control and file management, among others. This programming capability provides the greatest efficiency in label printing. The status of printer and error messages can be displayed on the LCD screen. Unlike its predecessors, this model features an LCD screen to facilitate the operation of the printer. This new feature enables the user to view printer status or set printing parameters directly on the printer unit in English, Chinese, Japanese, Italian...etc., making interfacing with the printer all the more simple and viable!

**Specifications, accessories, parts and programs are subject to change without notice.**

## 1.1 Compliances

CE:

EN55022:1998+A1: 2000+A2: 2003, Class A

EN55024: 1998+A1: 2001+A2: 2003 IEC 61000-4 Series

EN61000-3-2: 2000 & EN61000-3-3: 1995+A1: 2001

UL/CUL:

UL1950, File Number: 178707

## FCC Class A

This equipment has been tested and found to comply with the limits for a Class A digital device, pursuant to Part 15 of the FCC Rules. These limits are designed to provide reasonable protection against harmful interference when the equipment is operated in a commercial environment. This equipment generates, uses and can radiate radio frequency energy, and if not installed and used in accordance with the instruction manual, may cause harmful interference to radio communications. Operation of this equipment in a residential area is likely to cause harmful interference in which the user will be required to correct the interference at his or her own expense.

## TUV/ Safety:

EN60950, Certificate Number: AL990636129001

### Wichtige Sicherheits-Hinweise

1. Bitte lesen Sie diese Hinweis sorgfältig durch.
2. Heben Sie diese Anleitung für den späteren Gebrauch auf.
3. Vor jedem Reinigen ist das Gerät vom Stromnetz zu trennen. Verwenden Sie keine Flüssig-oder Aerosolreiniger. Am besten eignet sich ein angefeuchtetes Tuch zur Reinigung.
4. Die Netzanschluß-Steckdose soll nahe dem Gerät angebracht und leicht zugänglich sein.
5. Das Gerät ist vor Feuchtigkeit zu schützen.
6. Bei der Aufstellung des Gerätes ist auf sicheren Stand zu achten. Ein Kippen oder Fallen könnte Beschädigungen hervorrufen.
7. Beachten Sie beim Anschluß ans Stromnetz die Anschlußwerte.
8. Dieses Gerät kann bis zu einer Außentemperatur von maximal 40°C betrieben werden.

### **CAUTION**

- 1. HAZARDOUS MOVING PARTS IN CUTTER MODULE. KEEP FINGER AND OTHER BODY PARTS AWAY.**
- 2. THE MAIN BOARD INCLUDES REAL TIME CLOCK FEATURE HAS LITHIUM BATTERY CR2032 INSTALLED. RISK OF EXPLOSION IF BATTERY IS REPLACED BY AN INCORRECT TYPE.**
- 3. DISPOSE OF USED BATTERIES ACCORDING TO THE MANUFACTURER INSTRUCTIONS.**

## A급기기

(업무용 정보통신기기)

이 기기는 업무용으로 전자파 적합등록을 한 기기이오니, 판매자 또는 사용자는 이 점을 주위하시기 바라며, 만약 잘못 판매 또는 구입하였을 때에는 가정용으로 교환하시기 바랍니다.

## **2. GETTING STARTED**

### **2.1 Unpacking and Inspection**

This printer has been specially packaged to withstand damage in the shipping process. However, for fear that unexpected damage might occur, upon receiving the bar code printer, carefully inspect the package and the device. In case of evident damage, contact the carrier directly to specify the nature and extent of the damage. Please retain the packaging materials in case you need to reship the printer.

### **2.2 Equipment Checklist**

- Bar code printer unit
- Ribbon paper core
- Ribbon supply/rewind spindle (2 pcs.)
- Centronics port cable
- Power cord
- Software/Windows driver CD disk
- Quick start guide

Separately purchased items may also be included. These additional items may include:

- Labels
- Ribbons
- Memory module
- Cutter module
- Stand-alone keyboard

If any parts are missing, please contact the Customer Service Department of your purchased reseller or distributor.

## 2.3 Printer Parts

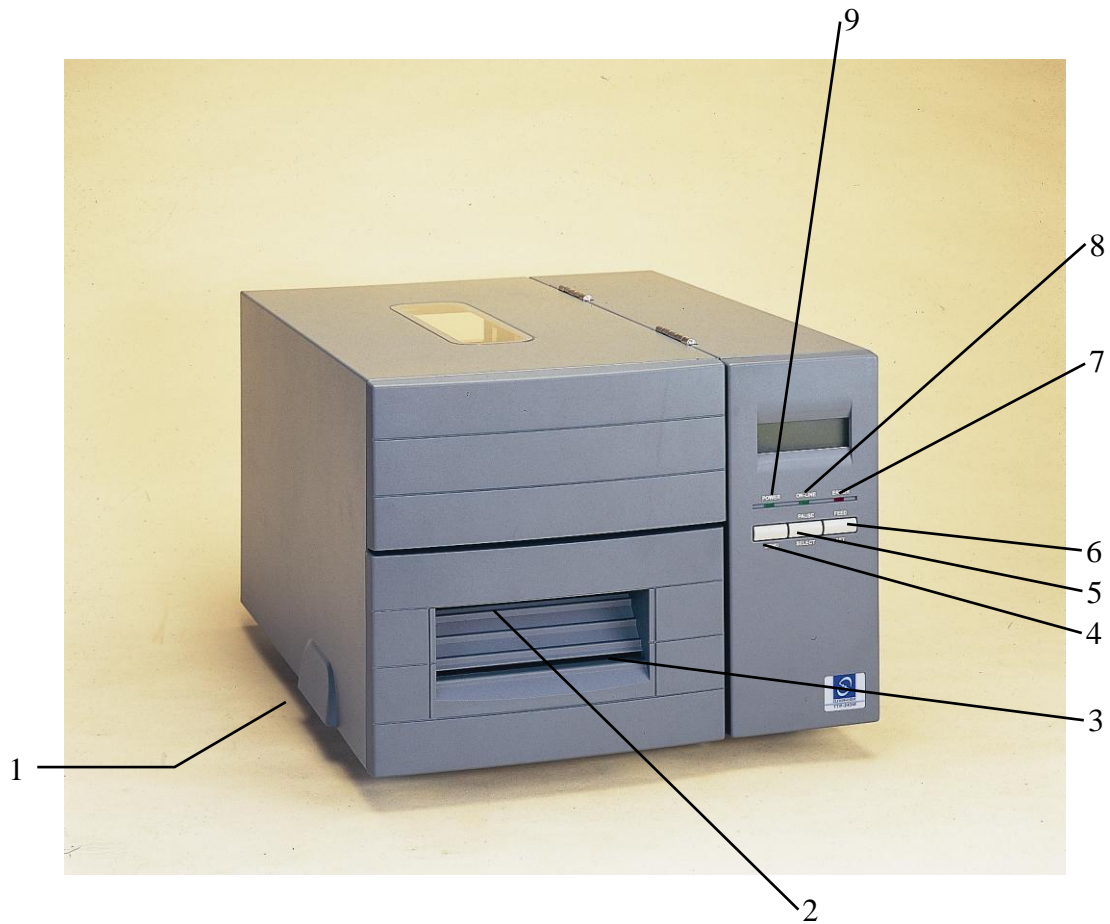

**Figure 1. Top Front View**

1. Cover Open/Release Handle
2. Label Dispense Opening
3. Backing Paper Opening
4. MENU Button
5. PAUSE/SELECT Button
6. FEED/SET Button
7. Error Indicator
8. On-line Indicator
9. Power Indicator

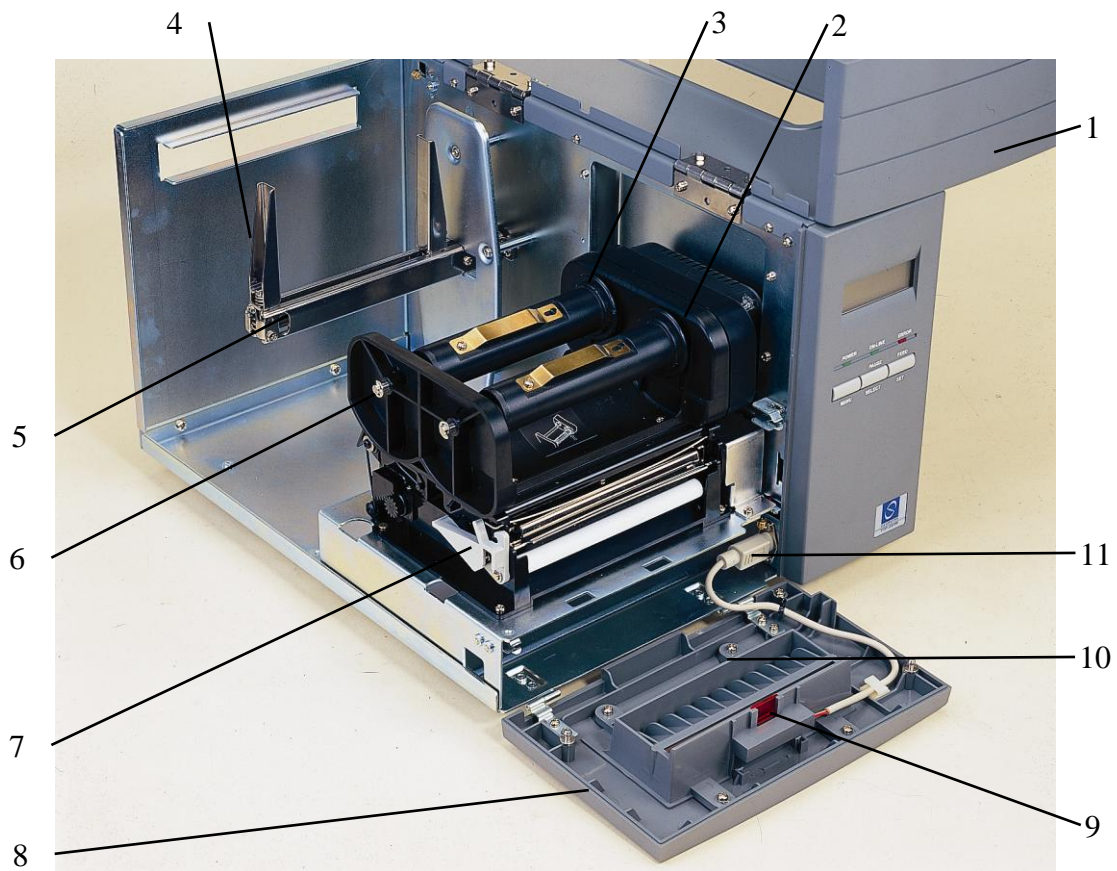

**Figure 2 Interior View**

1. Printer Cover (in open position)
2. Ribbon Rewind Spindle
3. Ribbon Supply Roll Spindle
4. Label Roll Guard
5. Label Supply Roll Spindle
6. Ribbon Mechanism
7. Carriage Release Lever
8. Front Panel
9. Peel Off Sensor
10. Backing Paper Opening
11. Peel-Off Sensor / Cutter Power Connector

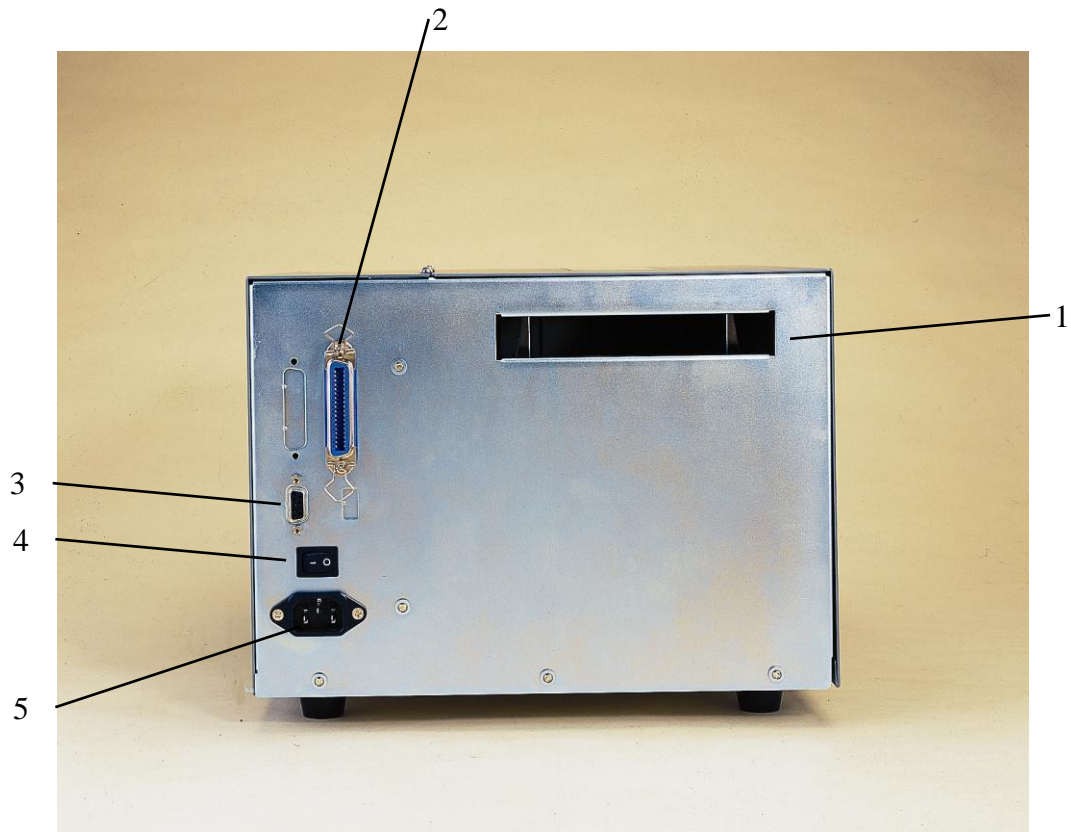

**Figure 3. Rear View**

1. Label Insert Opening (for use with external labels)
2. Centronics Interface Connector
3. RS-232C DB-9 Interface Connector
4. Power On/Off Switch
5. AC Power Cord Socket

## 2.4 Buttons and Indicators

### POWER Indicator

The green **POWER** indicator illuminates when the power switch is turned on.

### ON-LINE Indicator

The green **ON-LINE** indicator illuminates when the printer is ready to print. When the **PAUSE** button is pressed, the **ON-LINE** indicator flashes.

### ERROR Indicator (Error/Paper Empty)

The red **ERROR** indicator illuminates in the event of a printer error, such as paper empty, ribbon empty, out of memory, and so forth. For a full list of error messages, please refer to Section 4.2, Troubleshooting Guide.

### MENU Button

Provided with a built-in menu, the printer allows the user to directly set printing parameters or view printer status on the LCD display panel. To enter the Menu mode, press the **MENU** button. Press the button over again to proceed from one menu item to another or to revert to the original Ready status. The menu is comprised of these major items: **Printer Info, File List, Memory Info, Date/Time,** and **Printer Setup**. Each of said items, in turn, is made up of a number of sub-items, which can be selected by pressing the **SELECT** button, or viewed or set by pressing the **SET** button. Refer to Appendix for the structure and operation logic of the menu.

### PAUSE/SELECT Button

This button combines two functions: **PAUSE** if the printer is in the Ready status, or **SELECT** if in the Menu mode.

The **PAUSE** button allows the user to hold a print job and then resume the printing with a second depression of the button. By pressing the **PAUSE** button: (1) the printer stops at the completion of printing of the current label, (2) the **PAUSE** LED flashes, and (3) the printer holds all data in memory. This allows for trouble-free replacement of label stock and thermal transfer ribbon. A second depression of the **PAUSE** button will restart the printer.

**Note: If the PAUSE button is held down for more than 3 seconds, the printer will be reset and all data of the previous printing job will be lost.**

The **SELECT** button allows the user select for the sub-item to be processed. Once the sub-item has been selected, the user can change its setting by pressing the **SET** button.

### **FEED/SET Button**

As does the **PAUSE/SELECT** button, this button also has dual functions: **FEED** and **SET**.

Press the **FEED** button for label to advance to the next print position.

Press the **SET** button to change parameter settings or view printer status on the LCD screen.

## 3. SET UP

### 3.1 Setting Up the Printer

1. Place the printer on a flat, secure surface.
2. Make sure the power switch is off.
3. Connect the printer to the computer mainframe with the provided Centronics cable.
4. Plug the power cord into the AC power cord socket at the rear of the printer, and then plug the power cord into a properly grounded receptacle.

**Note:**

Please switch OFF printer power switch prior to plug in the power cord to printer power jack.

### 3.2 Loading Label Stock

1. Open the printer cover
2. Disengage the printer carriage by pulling the printer carriage release lever located to the left side of the platen.
3. Lower the label roll guard to the horizontal position, slide the label stock into label roll spindle, and then flip back the label roll guard.
4. Feed the label under the carriage and over the platen.
5. Adjust the label guide to fit the width of the media.
6. Engage the printer carriage.
7. Wind the label roll until it becomes adequately stretched for the intended purpose.
8. Close the printer cover and press the **FEED** button three or four times until the green **ON-LINE** indicator illuminates.
9. When the printer is out of ribbon or media, the **ON-LINE** LED will not illuminate and the **ERROR** LED will flash. Reload the ribbon or media without turning off the printer power. Press the **FEED** button three or four times until the **ON-LINE** LED illuminates. The printing job will be resumed without data loss.

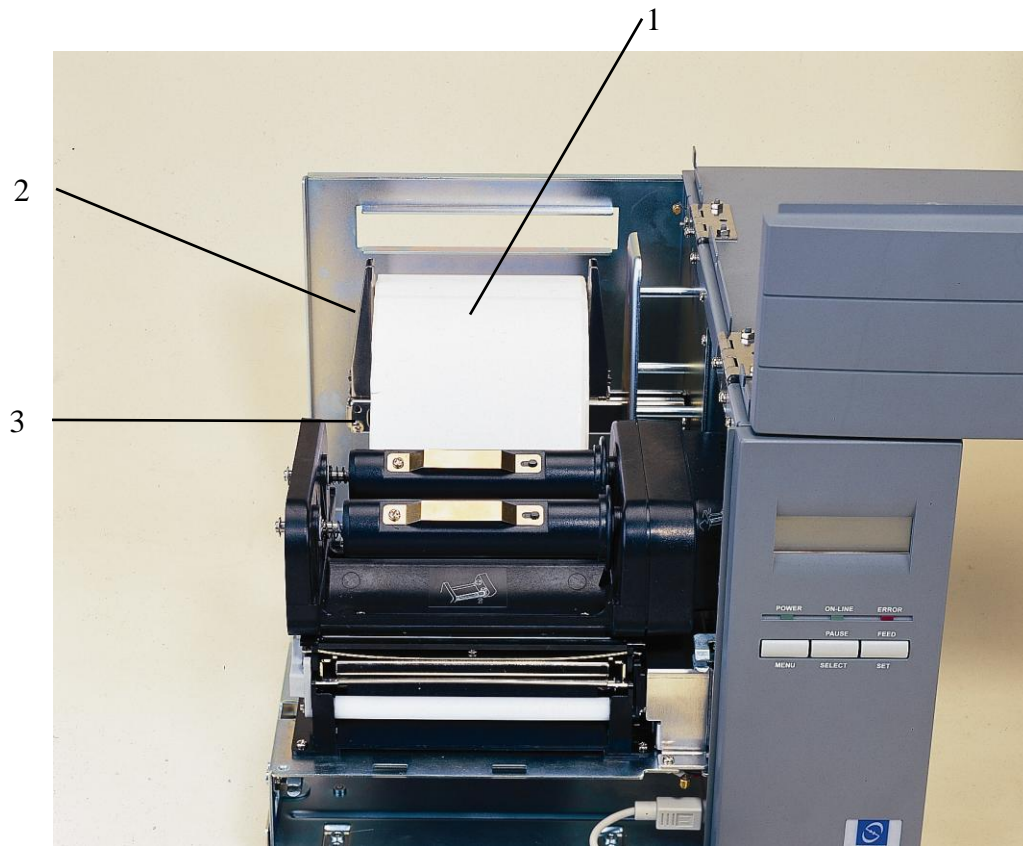

**Figure 4. Inserting Label Supply Roll Onto Label Roll Spindle**

1. Label Roll
2. Label Roll Guard
3. Label Supply Roll Spindle

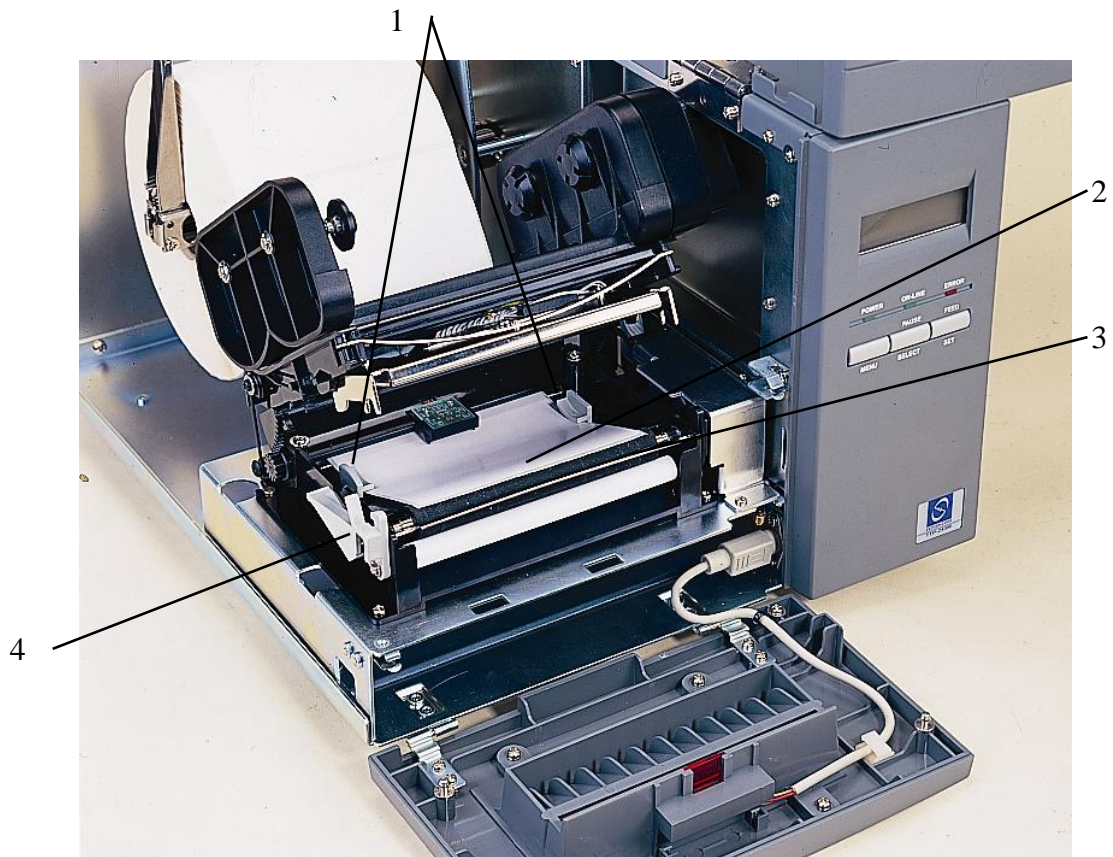

**Figure 5. Feeding Labels Through Adjustable Label Guide**

1. Adjustable Label Guide
2. Label Media
3. Platen
4. Printer Carriage Release Lever

### 3.3 Self-Peeling Function

(The self-peeling function and the cutter function cannot be installed at the same time. To uninstall the cutter, refer to Section 3.4)

To employ the self-peeling function, load the label stock according to the following steps.

1. Open the printer cover and front panel.
2. Tear off the foremost one or two labels of the label stock, as befits the case. Feed the backing paper between the platen and the white “self-peeling” roller, as shown in Figure 6.
3. Feed the backing paper through the backing paper opening in the front panel, as shown in Figure 7.
4. Close the front panel and printer cover.

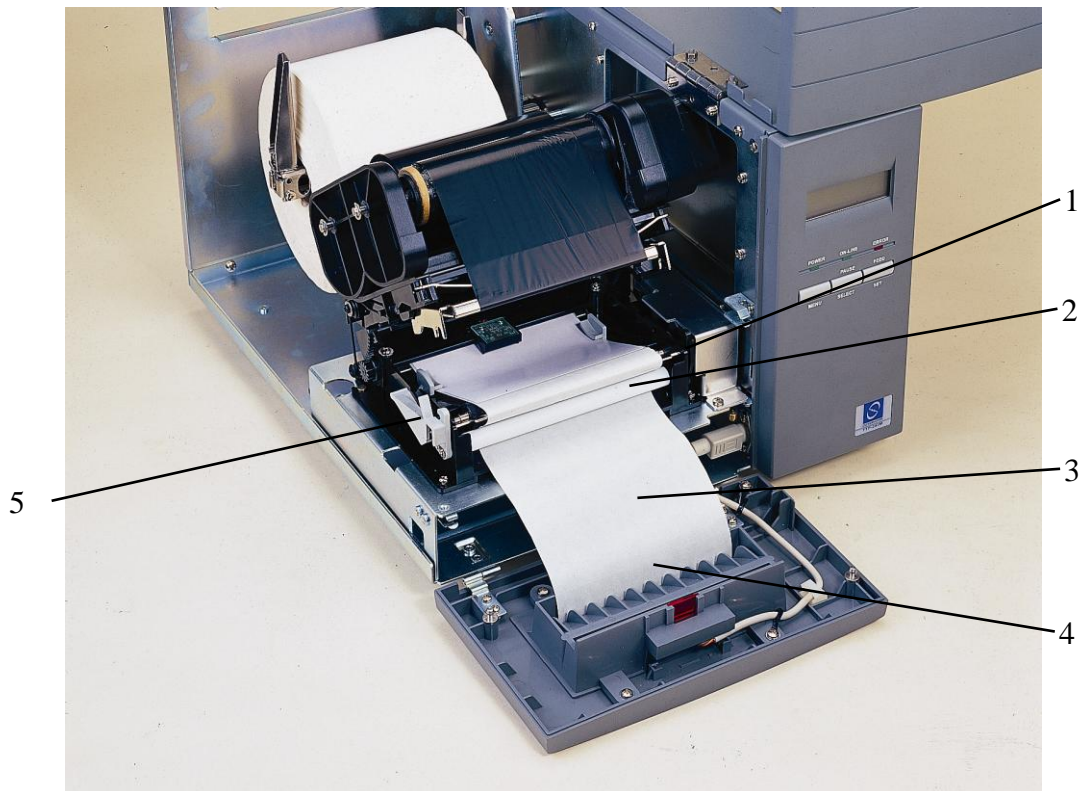

**Figure 6. Setting Up Printer for Self-Peeling Function**

1. Platen
2. Self-Peeling Roller
3. Backing Paper
4. Backing Paper Opening
5. Carriage Release Lever



**Figure 7. Printer Ready for Self-Peeling Function**

1. Printer Front Panel
2. Backing Paper Opening
3. Backing Paper
4. Printer Carriage Release Lever
5. Label (Media)

### 3.4 Cutter Function

(Unlike the aforesaid self-peeling function, the cutter function is not a standard device of this printer. To have this function, user should additionally purchase the cutter set, which includes a cutter module and a detachable front panel.)

To employ the cutter function, follow the steps below.

1. Open the printer cover and front panel.
2. Unfasten the front panel, replace it with the one that goes with the cutter module.
3. Install the cutter module. First fit the cutter module in the slits at the front edge of the carriage and slide the module to the right. After that, fix the cutter module in place with the provided tap screw; and then connect the cutter to the power connector below and to the right of the carriage.
4. Install the ribbon and feed the labels as shown.
5. Put back the front panel and top cover.

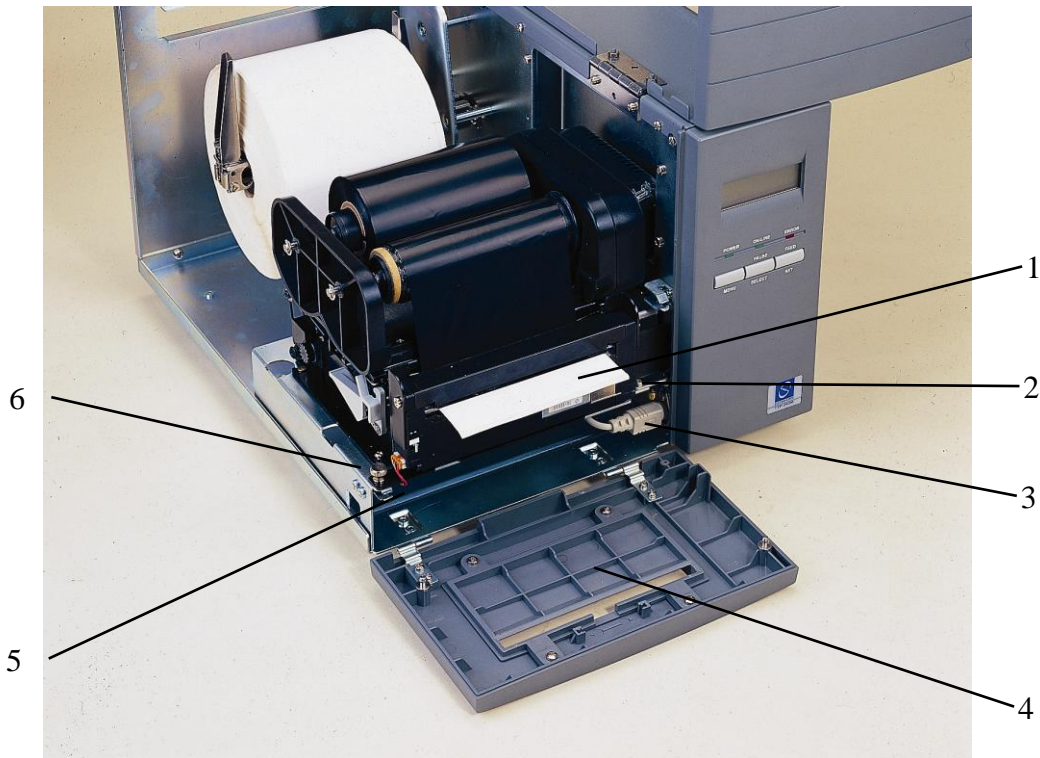

**Figure 8 Cutter Function Installation**

1. Label
2. Cutter Module
3. Cutter Power Connector
4. Cutter Mode Front Panel
5. Cutter Power Cord (Insert the cord in cord clips right under the carriage)
6. Screw

### 3.5 Ribbon Loading Instructions

1. Place an empty paper core on the ribbon rewind spindle.
2. Install the ribbon on the ribbon supply spindle.
3. Disengage the printer carriage.
4. Pull the ribbon leader to the front from beneath the printer carriage. Attach the ribbon leader to the ribbon rewind paper core (with a tape).
5. Rotate the ribbon rewind roller until the ribbon leader is thoroughly, firmly encompassed by the black section of the ribbon.
6. Engage the printer carriage.
7. Close the printer cover and press the **FEED** button until the green **ON-LINE** LED illuminates.



**Figure 9. Placement of Ribbon Supply Roll**

1. Thermal Transfer Ribbon
2. Ribbon Supply Spindle
3. Ribbon Rewind Spindle



**Figure 10. Installation of Label Stock and Thermal Transfer Ribbon**

## 3.6 Self Test

To initiate the self test mode, hold down the **FEED** button and activate the printer power simultaneously. The printer will calibrate the label length. If the label gap is not detected within 7", the printer stops feeding labels and the media is regarded as continuous paper. In self test, a check pattern is used to check the performance of the thermal print head. Following the check pattern, the printer prints its internal settings as listed below:

1. Printer model and firmware version
2. Mileage
3. Flash times
4. Check sum
5. Serial port setting
6. Code page setting
7. Country code setting
8. Print speed setting
9. Print density setting
10. Label size setting
11. Gap (Bline) width and offset setting
12. Backing paper transparenance
13. File list
14. Memory available

When the self test is completed, the printer enters the dump mode. Please turn the printer's power off and then on again to resume normal printing.

PRINTER INFO.

TTP244MEP Version: 1.01  
MILAGE(Km): 0.0688  
CHECKSUM: 02FF0D6B  
SERIAL PORT: 9600,N,8,1  
CODE PAGE: 437  
COUNTRY CODE: 001  
SPEED: 2 INCH  
DENSITY: 8  
SIZE: 4.10 , 8.00  
GAP: 0.11 , 0.00  
TRANSPARENCE: 85

\*\*\*\*\*

FILE LIST:

DRAM FILE:	0	FILE(S)
FLASH FILE:	0	FILE(S)
TOTAL FLASH:	1024	KBYTES
AVAIL FLASH:	1024	KBYTES
TOTAL DRAM:	256	KBYTES
AVAIL DRAM:	256	KBYTES

END OF FILE LIST:

\*\*\*\*\*

NOW IN DUMP MODE

**Note:**

*The physical flash memory and DRAM on board is 2MB respectively. Due to system firmware will occupy 1MB, so total available flash memory space for downloads is 1024 K bytes.*

*For DRAM, system and image buffer will occupy 1792 K bytes, so total available DRAM for downloads will be 256 K bytes.*

### 3.7 Dump Mode

After the self test, the printer enters the dump mode. In this mode, any characters sent from the host computer will be printed in two columns, as shown. The characters received will be shown in the first column, and their corresponding hexadecimal values, in the second. This is often helpful to users for the verification of programming commands or debugging of printer programs. Reset the printer by turning the **POWER** switch off and on.

```
*****
NOW IN DUMP MODE

DOWNLOAD "DE  44 4F 57 4E 4C 4F 41 44 20 22 44 45
MO2.BAS"  SI  4D 4F 32 2E 42 41 53 22 0D 0A 53 49
ZE 4.00,5.00 5A 45 20 34 2E 30 30 2C 35 2E 30 30
  CLS  SPEED  0D 0A 43 4C 53 0D 0A 53 50 45 45 44
  1.5  DENSIT 20 31 2E 35 0D 0A 44 45 4E 53 49 54
Y 10  DIRECT 59 20 31 30 0D 0A 44 49 52 45 43 54
ION 0  SET C  49 4F 4E 20 30 0D 0A 53 45 54 20 43
UTTER OFF S  55 54 54 45 52 20 4F 46 46 0D 0A 53
ET DEBUG LAB 45 54 20 44 45 42 55 47 20 4C 41 42
EL REFERENC  45 4C 0D 0A 52 45 46 45 52 45 4E 43
E 0,0  A=100  45 20 30 2C 30 0D 0A 41 3D 31 30 30
0 Y=100  FO   30 0D 0A 59 3D 31 30 30 0D 0A 46 4F
R I=1 TO 3    52 20 49 3D 31 20 54 4F 20 33 0D 0A
BARCODE 100,  42 41 52 43 4F 44 45 20 31 30 30 2C
Y, "39",96,1,  59 2C 22 33 39 22 2C 39 36 2C 31 2C
0,2,4,STR$(A  30 2C 32 2C 34 2C 53 54 52 24 28 41
) A=A+1 Y=    29 0D 0A 41 3D 41 2B 31 0D 0A 59 3D
Y+150  NEXT  59 2B 31 35 30 0D 0A 4E 45 58 54 0D
PRINT 1  EO   0A 50 52 49 4E 54 20 31 0D 0A 45 4F
P  DEMO2     50 0D 0A 44 45 4D 4F 32 0D 0A
```

## 4. USING THE PRINTER

### 4.1 Power-on Utilities

There are three power-on utilities to set up and test the printer hardware. These utilities are activated by pressing the **FEED** or **PAUSE** button and turning on the printer power simultaneously. The utilities are listed below:

1. Self test
2. Gap sensor calibration
3. Printer initialization

#### 4.1.1 Self Test Utility

Install the label first. Press the **FEED** button and then turn on the printer power. Do not release the **FEED** button until the printer feeds labels. The printer performs the following:

1. Calibrate label pitch
2. Print out thermal print head check pattern
3. Print the internal settings
4. Enter dump mode

For more information on self test and dump mode, refer to Section 3.6, Self Test, and Section 3.7, Dump Mode.

#### 4.1.2 Gap Sensor Calibration Utility

This utility is used to calibrate the sensitivity of the gap sensor. Users may have to calibrate the gap sensor on two occasions:

1. Changing to a new type of label media.
2. Initializing the printer.

**Note: The ERROR LED may flash if gap sensor is not calibrated properly.**

Please follow the steps below to calibrate the gap sensor:

1. Turn off the printer power and install blank labels (without any logo or character) on the printer.
2. Hold down the **PAUSE** button and turn on the printer power.
3. Release **PAUSE** button when the printer feeds labels. **Do not turn off the printer power** until the printer stops and the two green LEDs light on.

**Note: Black mark sensor has fixed sensitivity. It is no need to calibrate the black mark sensor**

### 4.1.3 Printer Initialization

Printer initialization clears all downloaded files resident in the flash memory and sets printer parameters to default values.

Parameter	Default Value
MILEAGE	Automatic
FLASH TIMES	Automatic
CHECK SUM	Automatic
SERIAL PORT	96,N,8,1
CODE PAGE	437 (8 bit), USA (7 bit)
COUNTRY CODE	001
SPEED	2.0"/sec (1.5"/sec, 342M)
DENSITY	8
SIZE	4"x2.5"
GAP(BLINE)	3 mm
TRANSPARANCY	Will be reset. Need to re-calibrate the gap sensor
LCD Language	English

Please follow the steps below to initialize the printer:

1. Turn off the printer power.
2. Hold down the **PAUSE** and **FEED** buttons and turn on the printer power.
3. Do not release the buttons until the three LEDs flash in turn.

**Note:**

***Printing method (thermal transfer or thermal direct printing ) will be set automatically at the activation of printer power.***

- ***Download files will be deleted after printer initialization.***
- ***Sensor calibration is required after printer initialization before printing labels.***

## 4.2 Troubleshooting Guide

The following guide lists some of the most common problems that may be encountered when operating the bar code printer. If the printer still does not function after all suggested solutions have been invoked, please contact the Customer Service Department of your purchased reseller or distributor for assistance

<b>Problem</b>	<b>Solution</b>
Ribbon does not advance or rewind	The media and ribbon must be installed and close print head mechanism prior to turning on printer power.
Poor print quality	Clean the thermal print head. Adjust the print density setting. Ribbon and media are not compatible. Media thickness is over spec.
Power indicator does not illuminate	Check the power cord, see whether it is properly connected.
<b>ON-LINE</b> indicator is off, <b>ERROR</b> indicator is on	Out of paper or out of ribbon Calibrate the sensitivity of gap sensor. Rewind ribbon paper core is not installed.
Continuous feeding when printing labels	Calibrate the gap sensor.



# Appendix A Menu Control Flowchart

The following shows the control flowchart of the menu.

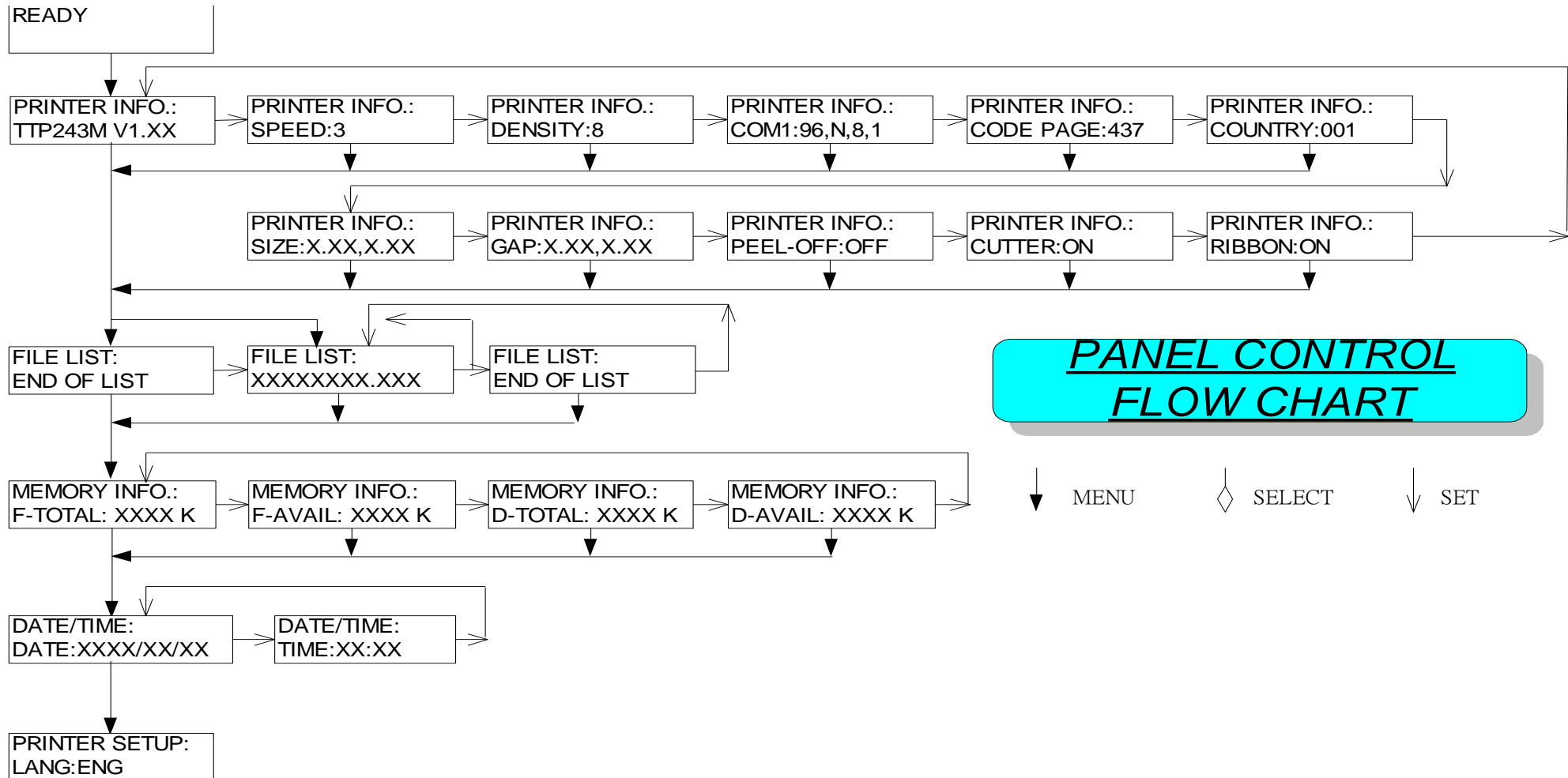

(Continued on next page)

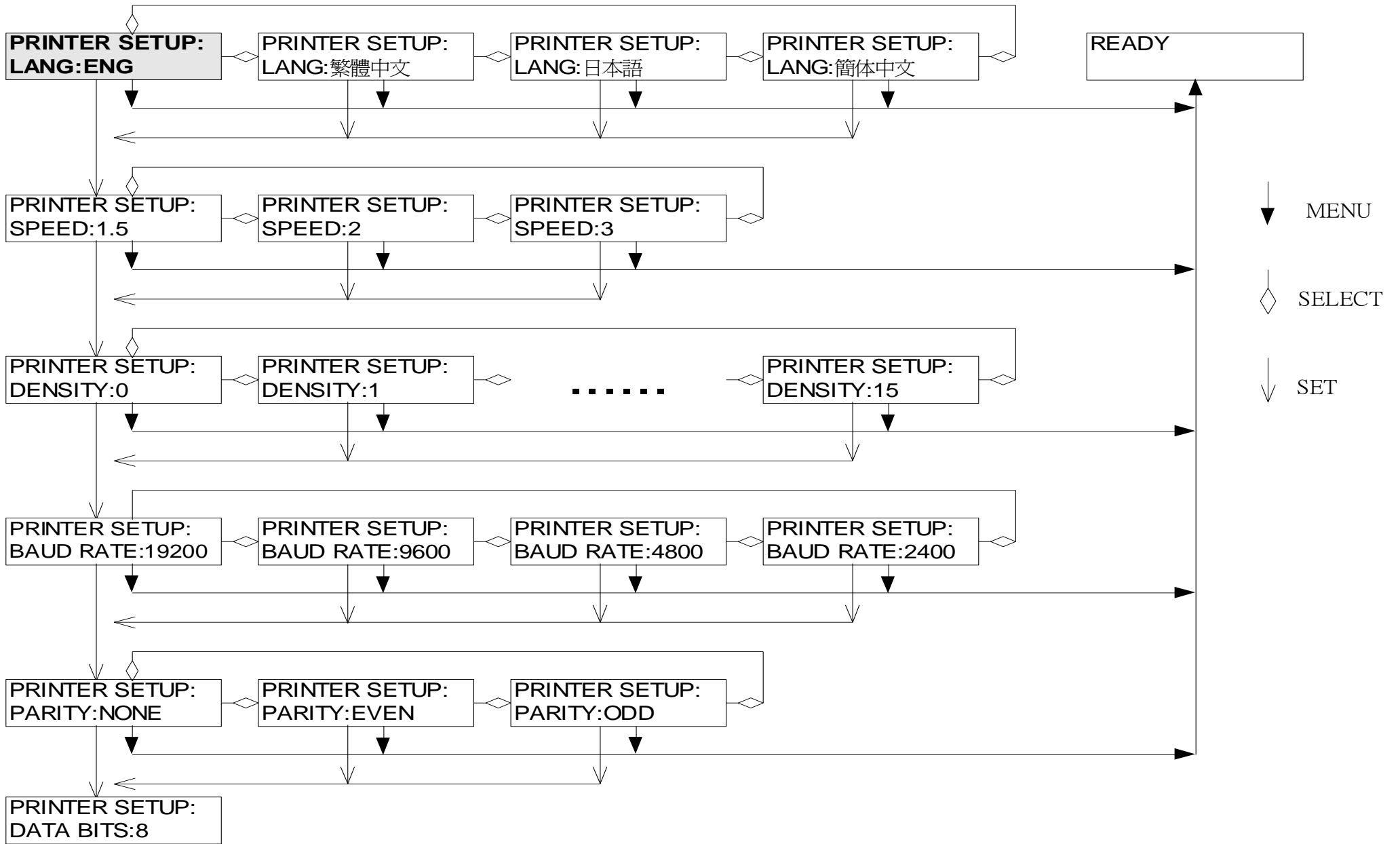

(Continued on next page)

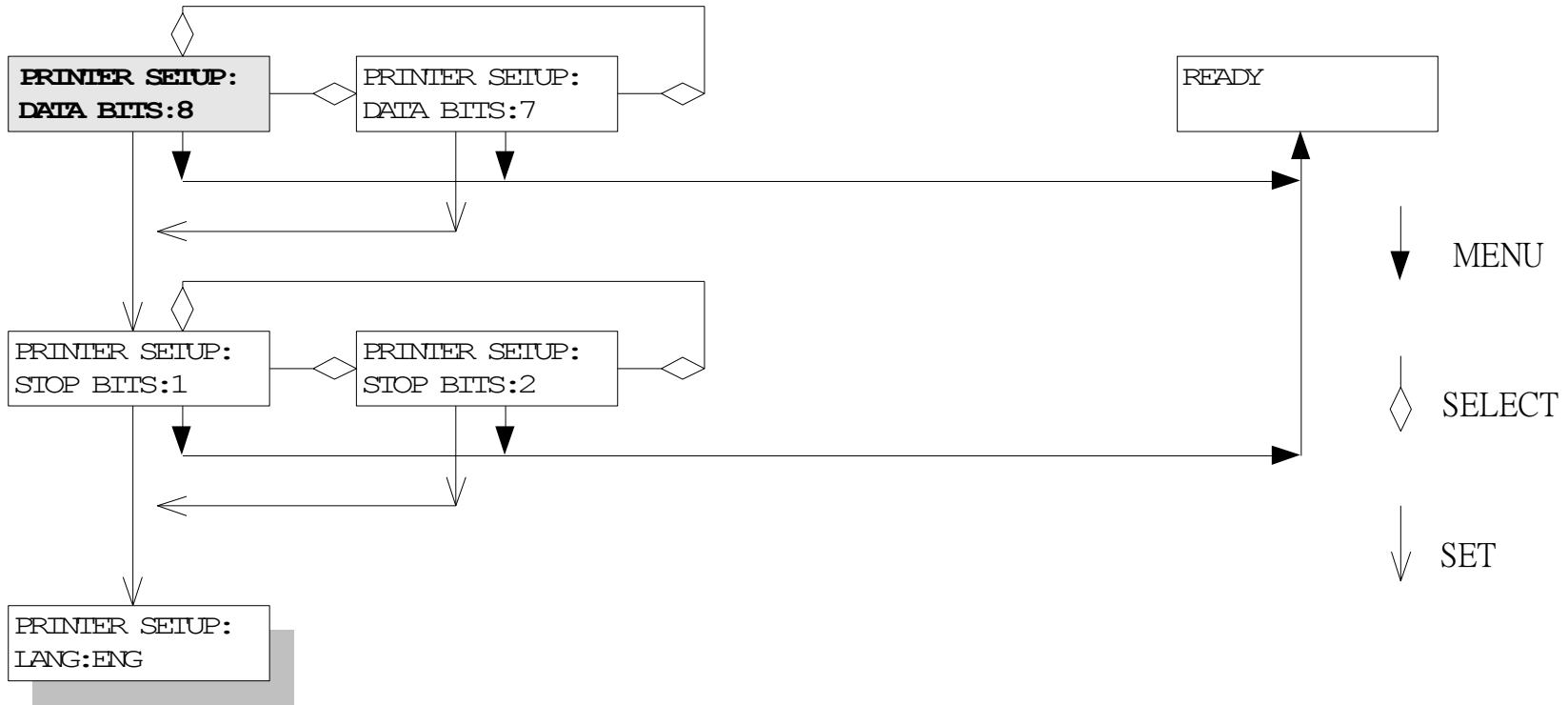



TSC Auto ID Technology Co., Ltd.

Corporate Headquarters  
9F., No.95, Minquan Rd., Xindian Dist.,  
New Taipei City 23141, Taiwan (R.O.C.)  
TEL: +886-2-2218-6789  
FAX: +886-2-2218-5678  
Web site: [www.tscprinters.com](http://www.tscprinters.com)  
E-mail: [printer\\_sales@tscprinters.com](mailto:printer_sales@tscprinters.com)  
[tech\\_support@tscprinters.com](mailto:tech_support@tscprinters.com)

Li Ze Plant  
No.35, Sec. 2, Ligong 1st Rd., Wujie Township,  
Yilan County 26841, Taiwan (R.O.C.)  
TEL: +886-3-990-6677  
FAX: +886-3-990-5577