

CipherLab User Guide

1500 Barcode Scanner

Setup labels included.

Version 1.03



Copyright © 2008 CIPHERLAB CO., LTD.
All rights reserved

The software contains proprietary information of CIPHERLAB CO., LTD.; it is provided under a license agreement containing restrictions on use and disclosure and is also protected by copyright law. Reverse engineering of the software is prohibited.

Due to continued product development this information may change without notice. The information and intellectual property contained herein is confidential between CIPHERLAB and the client and remains the exclusive property of CIPHERLAB CO., LTD. If you find any problems in the documentation, please report them to us in writing. CIPHERLAB does not warrant that this document is error-free.

No part of this publication may be reproduced, stored in a retrieval system, or transmitted in any form or by any means, electronic, mechanical, photocopying, recording or otherwise without the prior written permission of CIPHERLAB CO., LTD.

For product consultancy and technical support, please contact your local sales representative. Also, you may visit our web site for more information.

The CipherLab logo is a registered trademark of CIPHERLAB CO., LTD.

Microsoft, Windows, and the Windows logo are registered trademarks of Microsoft Corporation in the United States and/or other countries.

Bluetooth is a trademark of Bluetooth SIG, Inc., U.S.A.

Other product names mentioned in this manual may be trademarks or registered trademarks of their respective companies and are hereby acknowledged.

The editorial use of these names is for identification as well as to the benefit of the owners, with no intention of infringement.

CIPHERLAB CO., LTD.

Website: <http://www.cipherlab.com>

IMPORTANT NOTICES

FOR USA

This equipment has been tested and found to comply with the limits for a **Class B** digital device, pursuant to Part 15 of the FCC Rules. These limits are designed to provide reasonable protection against harmful interference in a residential installation. This equipment generates, uses and can radiate radio frequency energy and, if not installed and used in accordance with the instructions, may cause harmful interference to radio communications. However, there is no guarantee that interference will not occur in a particular installation. If this equipment does cause harmful interference to radio or television reception, which can be determined by turning the equipment off and on, the user is encouraged to try to correct the interference by one or more of the following measures:

- ▶ Reorient or relocate the receiving antenna.
- ▶ Increase the separation between the equipment and receiver.
- ▶ Connect the equipment into an outlet on a circuit different from that to which the receiver is connected.
- ▶ Consult the dealer or an experienced radio/TV technician for help.

This device complies with Part 15 of the FCC Rules. Operation is subject to the following two conditions: (1) This device may not cause harmful interference, and (2) this device must accept any interference received, including interference that may cause undesired operation.

FOR CANADA

This digital apparatus does not exceed the Class B limits for radio noise emissions from digital apparatus as set out in the interference-causing equipment standard entitled "Digital Apparatus," ICES-003 of Industry Canada.

This device complies with Part 15 of the FCC Rules. Operation is subject to the following two conditions: (1) This device may not cause harmful interference, and (2) this device must accept any interference received, including interference that may cause undesired operation.

Cet appareil numérique respecte les limites de bruits radioélectriques applicables aux appareils numériques de Classe B prescrites dans la norme sur le matériel brouilleur: "Appareils Numériques," NMB-003 édictée par l'Industrie.

FOR HAND-HELD PRODUCT WITH RF FUNCTIONS

This equipment complies with FCC radiation exposure limits set forth for an uncontrolled environment. This equipment should be installed and operated with minimum distance 20 cm between the radiator & your body. It only operated in hand-held used. If you only transfer data to Host by WLAN/Bluetooth, please keep the minimum distance 20 cm between machine & your body.

FOR PRODUCT WITH LASER

Per FDA and IEC standards, the scan engines described in this manual are not given a laser classification. However, the following precautions should be observed:



CAUTION

This laser component emits FDA / IEC Class 2 laser light at the exit port. Do not stare into beam.

SAFETY PRECAUTIONS

RISK OF EXPLOSION IF BATTERY IS REPLACED BY AN INCORRECT TYPE. DISPOSE OF USED BATTERIES ACCORDING TO THE INSTRUCTIONS.

- ▶ The use of any batteries or charging devices, which are not originally sold or manufactured by CipherLab, will void your warranty and may cause damage to human body or the product itself.
- ▶ DO NOT disassemble, incinerate or short circuit the battery.
- ▶ DO NOT expose the scanner or the battery to any flammable sources.
- ▶ For green-environment issue, it's important that batteries should be recycled in a proper way.
- ▶ Under no circumstances, internal components are self-serviceable.
- ▶ The charging and communication cradle uses an AC power adaptor. A socket outlet shall be installed near the equipment and shall be easily accessible. Make sure there is stable power supply for the mobile computer or its peripherals to operate properly.

CARE & MAINTENANCE

- ▶ Use a clean cloth to wipe dust off the scanning window and the body of the scanner as well as the cradle. DO NOT use/mix any bleach or cleaner.
- ▶ If you shall find the scanner malfunctioning, write down the specific scenario and consult your local sales representative.

RELEASE NOTES

Version	Date	Notes
1.03	Nov. 24, 2008	<ul style="list-style-type: none">▶ New: Quick Start – Flowchart▶ New: 1.3.2 Good Read LED Duration▶ Modified: 4.6 Multi-Barcode Editor – Reset scan mode to “Laser”▶ Modified: Host Serial Commands – adds D, E commands
1.02	Sep. 11, 2008	<ul style="list-style-type: none">▶ Modified: section 1.10 Auto-Sense Mode — add setup labels for improving sensitivity
1.01	July 23, 2008	<ul style="list-style-type: none">▶ Modified: section 1.2 Transmit Buffer — The use of transmit buffer is different from memory mode, and the latter is not supported by 1500 scanner!
1.00	May 26, 2008	Initial release

CONTENTS

- IMPORTANT NOTICES - 3 -**
 - For USA - 3 -
 - For Canada - 3 -
 - For Hand-held Product with RF Functions - 4 -
 - For Product with Laser - 4 -
 - Safety Precautions - 4 -
 - Care & Maintenance - 4 -

- RELEASE NOTES - 5 -**

- INTRODUCTION 1**
 - Inside the Package 2
 - Product Highlights 2

- QUICK START 3**
 - Enter Configuration Mode 4
 - Exit Configuration Mode 4
 - Default Settings 5
 - Save User Settings as Defaults 5
 - Restore User Defaults 5
 - Restore System Defaults 5
 - Read a Setup Label 6
 - Configure Parameters 6
 - List the Current Settings 10

- UNDERSTANDING THE BARCODE SCANNER 13**
 - 1.1 Power 13
 - 1.2 Transmit Buffer 13
 - 1.3 LED Indicator 14
 - 1.3.1 Good Read LED 14
 - 1.3.2 Good Read LED Duration 14
 - 1.4 Beeper 16
 - 1.4.1 Beeper Volume 16
 - 1.4.2 Good Read Beep 17
 - 1.5 Send “NR” to Host 18
 - 1.6 Scan Modes 19
 - 1.6.1 Continuous Mode 20
 - 1.6.2 Test Mode 21
 - 1.6.3 Laser Mode 21
 - 1.6.4 Auto Off Mode 21
 - 1.6.5 Auto Power Off Mode 22
 - 1.6.6 Aiming Mode 22
 - 1.6.7 Multi-Barcode Mode 23

1.7 Scanning Timeout.....	23
1.8 Delay between Re-read	24
1.9 Effective Decoding Area	25
1.9.1 Positioning Window	25
1.9.2 Adjusting Window	25
1.10 Auto-Sense Mode	27
1.11 Negative Barcodes	28
1.12 Symbologies Supported	28
1.12.1 Read Redundancy for All Symbologies	29
1.12.2 Addon Security for UPC/EAN Barcodes	30
SELECTING OUTPUT INTERFACE	31
2.1 Keyboard Wedge	32
2.1.1 Activate Keyboard Wedge & Select Keyboard Type	32
2.1.2 Keyboard Settings	33
2.1.3 Inter-Character Delay	39
2.1.4 Inter-Function Delay	39
2.2 RS-232	40
2.2.1 Activate RS-232 Interface	40
2.2.2 Baud Rate	40
2.2.3 Data Bits	41
2.2.4 Parity	41
2.2.5 Stop Bit	42
2.2.6 Flow Control	42
2.2.7 Inter-Character Delay	43
2.2.8 Inter-Function Delay	43
2.2.9 ACK/NAK Timeout	44
2.3 Wand Emulation	45
2.3.1 Activate Wand Emulation	45
2.3.2 Normal State	45
2.3.3 Bar State	45
2.3.4 Module Time	46
2.3.5 Margin Time	47
CHANGING SYMBOLOGY SETTINGS	49
3.1 Codabar	50
3.1.1 Start/Stop Characters Selection	50
3.1.2 Start/Stop Transmission	51
3.1.3 CLSI Conversion	51
3.2 Code 25 - Industrial 25	52
3.2.1 Start/Stop Pattern Selection	52
3.2.2 Checksum Verification	53
3.2.3 Checksum Transmission	53
3.2.4 Code Length Qualification	54
3.3 Code 25 - Interleaved 25	55
3.3.1 Start/Stop Pattern Selection	55
3.3.2 Checksum Verification	56
3.3.3 Checksum Transmission	56
3.3.4 Code Length Qualification	57
3.4 Code 25 - Matrix 25	58

3.4.1 Start/Stop Pattern Selection	58
3.4.2 Checksum Verification	59
3.4.3 Checksum Transmission.....	59
3.4.4 Code Length Qualification	60
3.5 Code 39.....	61
3.5.1 Start/Stop Transmission.....	61
3.5.2 Checksum Verification	61
3.5.3 Checksum Transmission.....	62
3.5.4 Standard/Full ASCII Code 39	62
3.6 Code 93.....	63
3.7 Code 128	63
3.8 EAN-8.....	64
3.8.1 Convert to EAN-13.....	65
3.8.2 Checksum Transmission.....	65
3.9 EAN-13	66
3.9.1 ISBN Conversion.....	67
3.9.2 ISSN Conversion.....	67
3.9.3 Checksum Transmission.....	67
3.10 EAN-128.....	68
3.10.1 Code ID Transmission.....	68
3.10.2 Field Separator (GS Character).....	68
3.11 ISBT 128	69
3.12 MSI	70
3.12.1 Checksum Verification.....	70
3.12.2 Checksum Transmission	71
3.12.3 Code Length Qualification	72
3.13 French Pharmacode.....	73
3.13.1 Checksum Transmission	73
3.14 Italian Pharmacode	74
3.14.1 Checksum Transmission	74
3.15 Plessey	75
3.15.1 Convert to UK Plessey	75
3.15.2 Checksum Transmission	75
3.16 RSS Family.....	76
3.16.1 Code ID Selection	76
3.16.2 RSS-14.....	76
3.16.3 RSS Expanded.....	77
3.16.4 RSS Limited.....	78
3.17 Telepen	80
3.17.1 Telepen Output – Full ASCII/Numeric	80
3.18 UPC-A.....	81
3.18.1 Convert to EAN-13	82
3.18.2 System Number Transmission	82
3.18.3 Checksum Transmission	82
3.19 UPC-E.....	83
3.19.1 System Number Selection.....	84
3.19.2 Convert to UPC-A.....	84
3.19.3 System Number Transmission	85
3.19.4 Checksum Transmission	85

DEFINING OUTPUT FORMAT	87
4.1 Letter Case	87
4.2 Character Substitution	88
4.2.1 Select a Set for Character Substitution	88
4.2.2 Symbologies for Character Substitution (All 3 Sets)	89
4.3 Prefix/Suffix Code	94
4.4 Code ID	95
4.4.1 Select Pre-defined Code ID	95
4.4.2 Change Code ID	96
4.4.3 Clear Code ID Settings	98
4.5 Length Code	99
4.6 Multi-Barcode Editor	102
4.6.1 Edit a Concatenation of Barcodes	103
4.6.2 Activate the Concatenation of Barcodes	104
APPLYING FORMATS FOR DATA EDITING	105
5.1 Format Selection	106
5.1.1 Activate Editing Formats	106
5.1.2 Exclusive Data Editing	107
5.2 Editing Format	108
5.2.1 Select Format to Configure	109
5.2.2 Restore Default Format	110
5.2.3 Define Data Criteria	111
5.2.4 Divide Data into Fields	114
5.2.5 Field Settings	116
5.2.6 Field Transmission Sequence	122
5.3 Programming Examples	124
5.3.1 Example I	124
5.3.2 Example II	125
SPECIFICATIONS	127
UPGRADING FIRMWARE	129
HOST SERIAL COMMANDS	131
Serial Commands	131
Example	132
KEYBOARD WEDGE TABLE	133
Key Type	133
Key Status	134
User-defined Scan Code	134
NUMERAL SYSTEMS	135
Decimal System	135
Hexadecimal System	136
ASCII Table	137

INTRODUCTION

CipherLab's new small-form-factor 1500 Barcode Scanners are specifically designed to answer your mobile demands. The tethered handheld scanners are designed to help accelerate productivity while lowering the total cost of ownership. Intensive data collection jobs are made easier with fast, accurate barcode scanning in various working environments, especially in small businesses.

Owing to the compact design, extremely low power consumption, and powerful decoding capability, CipherLab Barcode Scanners are the best choice for the following applications –

- ▶ Receiving in Retail
- ▶ Product labeling & Tracking
- ▶ Shelf Product Replenishment
- ▶ Mobile Point of Sale (POS)
- ▶ Mobile Inventory Management
- ▶ Order Picking & Staging
- ▶ Work-In-Process Tracking
- ▶ Material Flow Control
- ▶ Transportation & Distribution
- ▶ Warehousing
- ▶ Asset Management

This manual contains information on operating the scanner and using its features. We recommend you to keep one copy of the manual at hand for quick reference or maintenance purposes. To avoid any improper disposal or operation, please read the manual thoroughly before use.

Thank you for choosing CipherLab products!



INSIDE THE PACKAGE

The items included in the package may be different, depending on your order. Rich choices of output interfaces are available for you to enhance the total performance of the scanner. Refer to product specifications.

Save the box and packaging material for future use in case you need to store or ship the scanner.

- ▶ 1500 Barcode Scanner
- ▶ Manual & Driver CD

Note: (1) You will need to purchase one or more interface cable separately. For USB Virtual COM (Part #308), find the associated driver on the CD.
(2) The Manual & Driver CD includes this manual, Windows-based *ScanMaster* software for configuration, as well as 308 driver.

PRODUCT HIGHLIGHTS

- ▶ Small-form-factor and built tough to survive drop test
- ▶ Extremely low power consumption
- ▶ Firmware upgradeable
- ▶ Supports most popular barcode symbologies, including Reduced Space Symbology (RSS)
- ▶ Supports negative barcodes
- ▶ Supports seven scan modes, including Aiming Mode and Multi-Barcode Mode
- ▶ User feedback via LED indicator and beeper
- ▶ Beeping tone and duration programmable for Good Read
- ▶ Provides choices of output interfaces, including RS-232, Keyboard Wedge, and Wand Emulation.
- ▶ Programmable parameters include data output format, editing format, symbologies, etc.



QUICK START

The configuration of the scanner can be done by reading the setup labels contained in this manual or via the *ScanMaster* software.

This section describes the procedure of configuring the scanner by reading the setup barcodes and provides some examples for demonstration.

Note: If RS-232 is selected for output interface, the host can directly send serial commands to configure the scanner.

For example, run HyperTerminal.exe and type the 6-digit command located under each setup label. Refer to [Appendix II Host Serial Commands](#).

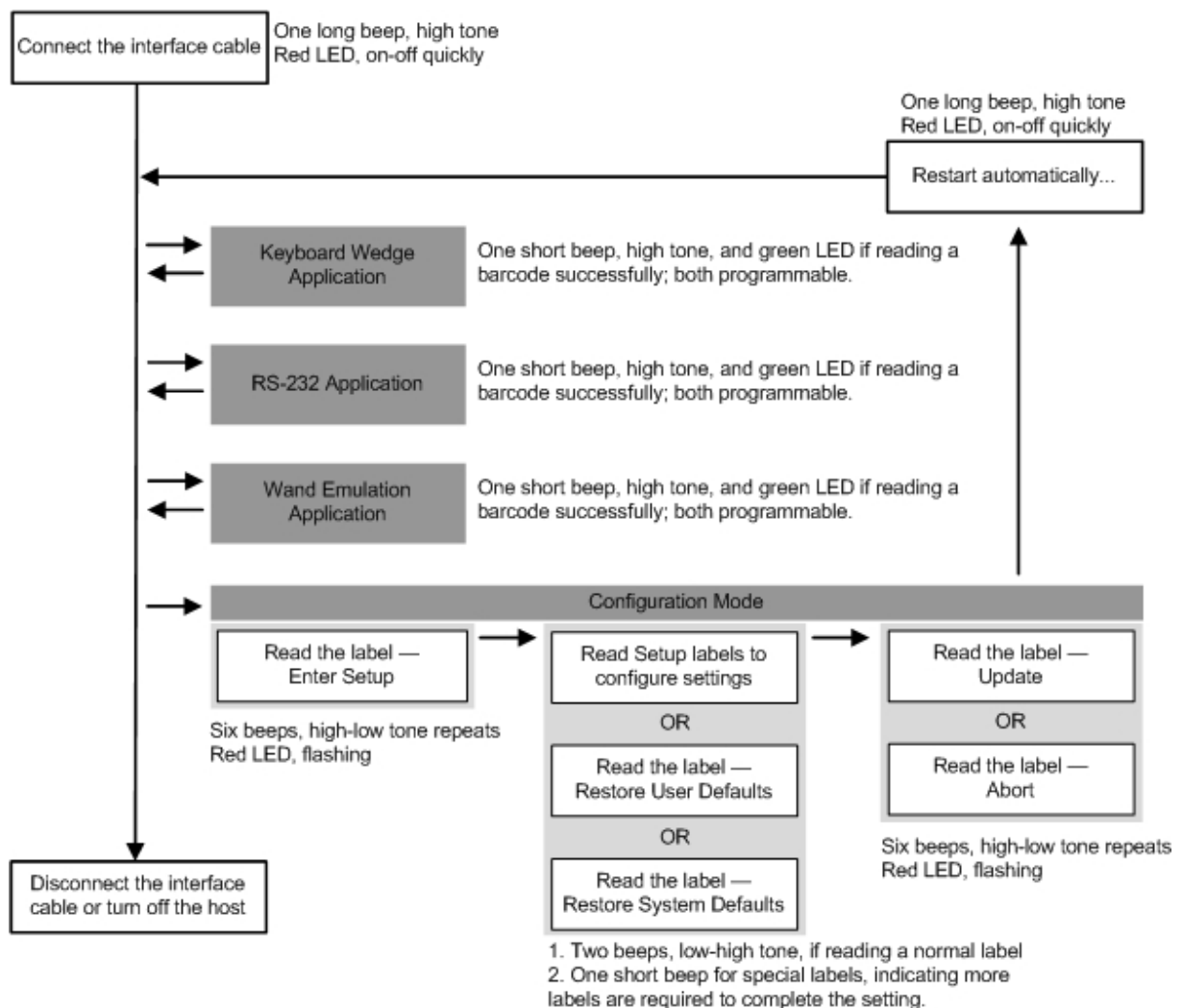

ENTER CONFIGURATION MODE

For the scanner to enter the configuration mode, you must have it read the "Enter Setup" label, which can be located at the bottom of almost every even page of this manual.

- ▶ The scanner will respond with six beeps and its LED indicator will become flashing red after reading the label.



For configuring scanner parameters, see "Read a Setup Label" below.

EXIT CONFIGURATION MODE

For the scanner to exit the configuration mode, you must have it read the "Update" label, which can be located at the bottom of almost every odd page of this manual. If you want to exit the configuration mode without saving any changes, have the scanner read the "Abort" label instead.

- ▶ Just like reading the "Enter Setup" label, the scanner will respond with six beeps and its LED indicator will become flashing red after reading the label. Wait for a few seconds for the scanner to restart itself.



DEFAULT SETTINGS

SAVE USER SETTINGS AS DEFAULTS

For the scanner to keep the customized settings as user defaults, you must have it read the “Save as User Defaults” label. This is a normal label, and the scanner will respond with two beeps (low-high tone).

- ▶ After reading the “Update” label, the current settings will be saved as user defaults.

Save as User Defaults



109986

RESTORE USER DEFAULTS

For the scanner to restore the user defaults, which you have saved earlier, you must have it read the “Restore User Defaults” label. This is a normal label, and the scanner will respond with two beeps (low-high tone).

- ▶ After reading the “Update” label, all the parameters of the scanner will return to their customized values.

Restore User Defaults



109987

RESTORE SYSTEM DEFAULTS

For the scanner to restore the factory defaults, you must have it read the “Restore System Defaults” label. This is a normal label, and the scanner will respond with two beeps (low-high tone).

- ▶ After reading the “Update” label, all the parameters of the scanner will return to their default values.

Restore System Defaults



109993

Note: The system default value (if there is) for each setting is indicated by an asterisk “*”.



READ A SETUP LABEL

CONFIGURE PARAMETERS

For most of the scanner parameters, only one read is required to set them to new values. The scanner will respond with two beeps when each parameter is set successfully.



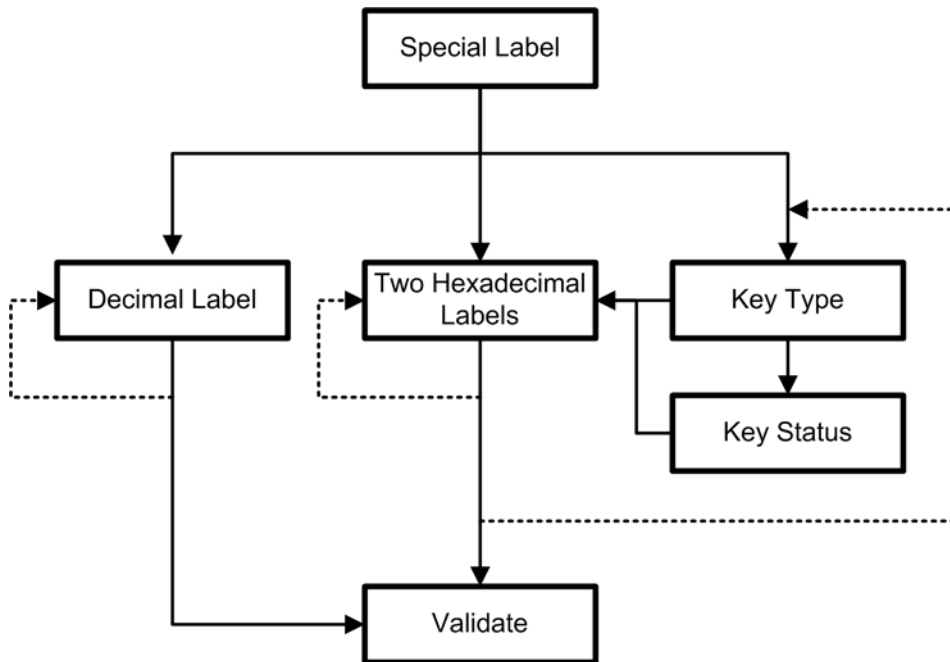

But for a number of special parameters, multiple reads are required to complete the setting. In this case, the scanner will respond with a short beep to indicate it needs to read more setup labels. These special parameters may require reading one or more setup labels, such as

- ▶ Numeric labels, say, for keyboard type, inter-character delay, length qualification
- ▶ Hexadecimal labels, say, for character strings as prefix, suffix, etc.
- ▶ When “Keyboard Wedge” is configured for interface, Key Type and Key Status will then become applicable. You may decide whether or not to change key status when “Normal Key” is selected for Key Type.

To complete the configuration of these special parameters, it requires reading the “Validate” label, and the scanner will respond with two beeps (low-high tone) to indicate the input values are validated.









The example below shows how to save your settings as “User Default” so that you may restore user defaults at a later time:

Steps	Action	User Feedback if Successful
1	Power on the scanner...	The scanner will respond with a long beep (high tone) and its LED indicator will become solid red and go off quickly.
2	Enter the Configuration Mode...	The scanner will respond with six beeps (high-low tone repeats three times), and its LED indicator will be flashing red.
3	Read a Setup label... For example,	The scanner will respond with two beeps (low-high tone) if reading a normal label.
	<p style="text-align: center;">Enter Setup</p>  <p style="text-align: center;">*Enable Industrial 25</p>  <p style="text-align: center;">100307</p> <p style="text-align: center;">Save as User Default</p>  <p style="text-align: center;">109986</p>	
4	Exit the Configuration Mode...	Same as for <i>Enter the Configuration Mode</i> .
	<p style="text-align: center;">Update Abort</p>  <p style="text-align: center;">109989 OR 109998</p>	
5	The scanner will automatically restart itself...	Same as for <i>Power on the scanner</i> .
*	When any configuration error occurs...	The scanner will respond with one long beep (low tone).











The example below shows how to set numeric parameters:

Steps	Action	User Feedback if Successful
1	Power on the scanner...	The scanner will respond with a long beep (high tone) and its LED indicator will become solid red and go off quickly.
2	Enter the Configuration Mode...	The scanner will respond with six beeps (high-low tone repeats three times), and its LED indicator will become flashing red.
3	Read a Setup label... For example,	The scanner will respond with two beeps (low-high tone) if reading a normal label.
Normal label	<p>*Enable Interleaved 25</p>  <p>100309</p>	
	Normal label	<p>Enable Fixed Length(s) ...</p>  <p>100604</p>
Special label		<p>Max. Length (*126) Or Fixed Length 1</p>  <p>100606</p>
	Decimal label or labels	<p>1</p>  <p>109901</p>
<p>5</p>  <p>109905</p>		
<p>Validate</p>  <p>109994</p>		The scanner will respond with two beeps (low-high tone) when the input values are validated.
4	Exit the Configuration Mode...	Same as for <i>Enter the Configuration Mode</i> .
5	The scanner will automatically restart itself...	Same as for <i>Power on the scanner</i> .



The example below shows how to set string parameters:

Steps	Action	User Feedback if Successful
1	Power on the scanner...	The scanner will respond with a long beep (high tone) and its LED indicator will become solid red and go off quickly.
2	Enter the Configuration Mode...	The scanner will respond with six beeps (high-low tone repeats three times), and its LED indicator will become flashing red.
3	Read a Setup label... For example,	The scanner will respond with one short beep if reading a special label such as "Prefix Code", indicating the setup requires reading more labels.
Special label	<p>Configure Prefix</p>  <p>101230</p>	When "Keyboard Wedge" is configured for interface, Key Type and Key Status will then become applicable. You may decide whether or not to change key status when "Normal Key" is selected for Key Type. ▶ Refer to Appendix III
	<p>*Normal</p>  <p>109926</p>	
	<p>Add Left Alt</p>  <p>109932</p>	
Hexadecimal labels	<p>2</p>  <p>109902</p>	Read the "Hexadecimal Value" labels for the desired character string. For example, read "2" and "B" for the scanner to prefix the character "+".
	<p>B</p>  <p>109911</p>	▶ Refer to Appendix IV "Hexadecimal System"
	<p>Validate</p>  <p>109994</p>	The scanner will respond with two beeps (low-high tone) when the input values are validated.
4	Exit the Configuration Mode...	Same as for <i>Enter the Configuration Mode</i> .
<p>Update</p>  <p>109999</p> <p>OR</p> <p>Abort</p>  <p>109998</p>	Same as for <i>Power on the scanner</i> .	
5	The scanner will automatically restart itself...	Same as for <i>Power on the scanner</i> .



Update

LIST THE CURRENT SETTINGS

The current settings of all scanner parameters can be sent, via RS-232, to the host computer for user inspection. The listing includes ten pages as shown below. You can select the page of interest by having the scanner read the "List Page x" label. The scanner will respond with two beeps (low-high tone) and send the selected page to the host immediately.

List Page 1  109950	List settings regarding Interface, Buzzer, and Other Scanner Parameters
List Page 2  109951	List settings regarding Prefix, Postfix, and Length Code Setting
List Page 3  109952	List settings regarding Code ID
List Page 4  109953	List settings regarding: Readable Symbologies
List Page 5  109954	List settings regarding Symbology Parameters (1/3)
List Page 6  109955	List settings regarding Symbology Parameters (2/3)
List Page 7  109956	List settings regarding Symbology Parameters (3/3)



List Page 8



109957

List settings regarding Editing Format 1

List Page 9



109958

List settings regarding Editing Format 2

List Page 10



109959

List settings regarding Editing Format 3

List Page 11



109937

List settings regarding Editing Format 4

List Page 12



109938

List settings regarding Editing Format 5





UNDERSTANDING THE BARCODE SCANNER

This chapter explains the features and usage of the barcode scanner.

IN THIS CHAPTER

1.1 Power	13
1.2 Transmit Buffer	13
1.3 LED Indicator	14
1.4 Beeper	16
1.5 Send "NR" to Host	18
1.6 Scan Modes	19
1.7 Scanner Time-out	23
1.8 Delay between Re-read.....	24
1.9 Effective Decoding Area	25
1.10 Auto-Sense Mode.....	27
1.11 Negative Barcodes	28
1.12 Symbologies Supported	28

1.1 POWER

Connect the interface cable between the 1500 scanner and your computer.

- ▶ If using the RS-232 cable, you must join the power supply cord to power up the scanner.
- ▶ The scanner will respond with one long beep (high tone) and its LED indicator will become solid red and go off quickly.

1.2 TRANSMIT BUFFER

The scanner is designed to send any collected data to a host computer one by one via the transmit buffer (SRAM). Upon reading a barcode successfully, the scanner responds with one short beep (high tone) and its LED indicator becomes solid green and goes off quickly. However, the host computer may not receive the data immediately if using a low baud rate or waiting for handshake signal (flow control). With the 4 KB transmit buffer, the scanner can ignore the transmission status and keep on reading barcodes until the buffer is full. A warning is given when the transmit buffer is full — the scanner will respond with one long beep (low tone) and its LED indicator will become solid red and go off quickly.

Note: The 4 KB transmit buffer on the scanner can hold as many as 256 scans based on EAN-13 barcodes. Data will be cleared out once the power adaptor to the RS-232 cable is removed or other interface cable is disconnected!



1.3 LED INDICATOR

The dual-color LED on top of the scanner is used to provide user feedback. For example, the LED becomes solid red and goes off quickly (= Standby mode) upon powering on or running out of transmit buffer. You may tell the difference by the beeps – for example, you will hear a long beep of high tone when powering on the scanner, and a long beep of low tone when the transmit buffer becomes full.

LED – Red/Green	Meaning
Red, and goes off quickly	<ul style="list-style-type: none"> ▶ Power on, with one long beep (high tone) ▶ Transmit buffer full, with one long beep (low tone) ▶ RS-232 connection fails, with two beeps (high-low tone)
Green, and goes off quickly	Good Read, with one short beep (high tone) and beeper pitch and duration programmable
Flashing red	Configuration Mode

1.3.1 GOOD READ LED

*Enable Good Read LED



Disable Good Read LED



1.3.2 GOOD READ LED DURATION

By default, the Good Read LED stays on for 40 milliseconds. Specify a value, ranging from 1 to 254 in units of 10 milliseconds.

Good Read LED Time-Out after
0.01~2.54 seconds (*40 ms)



- 1) Read the label above to specify the time interval before the Good Read LED goes off.



- 2) Read the "[Decimal Value](#)" label on page 135. For example, read "1" and "5" for the Good Read LED to go off after 150 milliseconds.
- 3) Read the "Validate" label on the same page to complete this setting.



1.4 BEEPER

The scanner has a buzzer to provide user feedback in various operating conditions.

Beeping	Meaning
One long beep, high tone	Power on, with red LED on and off quickly
One short beep, high tone ▶ Programmable, default to 4 KHz	Good Read, with green LED on and off quickly
Six short beeps ▶ High-low tone repeats three times	▶ Enter Configuration Mode, with red LED flashing ▶ Exit Configuration Mode
Two beeps, low-high tone	Setup label read successfully
Two beeps, high-low tone	RS-232 connection fails (data saved in Transmit Buffer), with red LED on and off quickly
One short beep, high tone	More setup label required
One long beep, low tone	▶ Transmit Buffer Full, with red LED on and off quickly ▶ Configuration Error (Wrong label...)
Two long beeps, high-low tone	Multi-Barcode Mode – Buffer Full

1.4.1 BEEPER VOLUME

Mute



Minimum Volume



Medium Volume



*Maximum Volume



1.4.2 GOOD READ BEEP

Frequency



Duration



1.5 SEND "NR" TO HOST

This feature only works when Keyboard Wedge, RS-232, Bluetooth HID, or Bluetooth SPP is selected for output interface. You may have the scanner send the "NR" string to the host to notify the No Read event.



1.6 SCAN MODES

There are seven scan modes supported – select the scan mode that best suits the requirements of a specific application. Refer to the comparison table below.

Scan Mode	Start to Scan				Stop Scanning			
	Always	Press trigger once	Hold trigger	Press trigger twice	Release trigger	Press trigger once	Barcode being read	Timeout
Continuous mode	✓							
Test mode	✓							
Laser mode			✓		✓		✓	✓
Auto Off mode		✓					✓	✓
Auto Power Off mode		✓						✓
Aiming mode				✓			✓	✓
Multi-Barcode mode			✓		✓			

Note: By default, the scan mode is set to Laser mode.



1.6.1 CONTINUOUS MODE

The scanner is always scanning.

- ▶ After a successful decoding, the removal of barcode is required. It is not allowed to proceed to decode until the decoding delay time has passed.
- ▶ To decode the same barcode repeatedly, move away the barcode and put it back again and again for scanning.

Note: Refer to "Delay between Re-read".

Continuous Mode



Decoding Delay

Set the time interval between each decoding.



1.6.2 TEST MODE

The scanner is always scanning.

- ▶ Capable of decoding the same barcode repeatedly without removing it, for testing purpose.



1.6.3 LASER MODE

The scanner will start scanning once the trigger is hold down.

- ▶ The scanning won't stop until (1) a barcode is decoded, (2) the pre-set timeout expires, or (3) you release the trigger.

Note: Refer to "Scanning Timeout".



1.6.4 AUTO OFF MODE

The scanner will start scanning once the trigger is pressed.

- ▶ The scanning won't stop until (1) a barcode is decoded, and (2) the pre-set timeout expires.

Note: Refer to "Scanning Timeout".



1.6.5 AUTO POWER OFF MODE

The scanner will start scanning once the trigger is pressed.

- ▶ The scanning won't stop until the pre-set timeout expires, and, the pre-set timeout period re-counts after each successful decoding.

Note: Refer to "Delay between Re-read" and "Scanning Timeout".

Auto Power Off Mode



100202

1.6.6 AIMING MODE

The scanner will aim at a barcode once the trigger is pressed, and start scanning when the trigger is pressed again within one second.

- ▶ The scanning won't stop until (1) a barcode is decoded, and (2) the pre-set timeout expires.

Aiming Mode



100208

Aiming Timeout

You can limit the aiming time interval (1~15). By default, the scanner time-out is set to 1 second.

Aiming Time-Out after 1~15 seconds (*1)



100226

1. Read the label above to specify the time interval before aiming ends. (It is set to 1 by default.)
2. Read the "[Decimal Value](#)" label on page 135. For example, read "1" and "0" for the scanner to automatically shut down after being idle for 10 seconds.
3. Read the "Validate" label on the same page to complete this setting.



1.6.7 MULTI-BARCODE MODE

The scanner will be scanning as long as the trigger is held down, capable of decoding not only one single barcode but a concatenation of unique barcodes.

- ▶ The scanning won't stop until you release the trigger.

Multi-Barcode Mode



Note: (1) A barcode is considered unique when its Code Type or data is different from others.

(2) Multi-Barcode Mode has nothing to do with the [Multi-Barcode Editor](#).

1.7 SCANNING TIMEOUT

Specify the scanning time interval (1~254 sec.; 0= Disable) when the scan mode is set to any of the following –

- ▶ Laser mode
- ▶ Auto Off mode
- ▶ Auto Power Off mode
- ▶ Aiming mode

Scanner Time-Out after 0~254 seconds (*10)



- 1) Read the label above to specify the time interval before the scan engine times out.
- 2) Read the “[Decimal Value](#)” label on page 135. For example, read “1” and “5” for the scanner to automatically shut down after being idle for 15 seconds.
- 3) Read the “Validate” label on the same page to complete this setting.



1.8 DELAY BETWEEN RE-READ

This is also referred to as the “Blocking Time”, which is used to prevent the scanner from accidentally reading the same barcode twice when the scan mode is set to any of the following –

- ▶ Continuous mode
- ▶ Auto Power Off mode



1.9 EFFECTIVE DECODING AREA

By default, the effective decoding area is 100% covered by the scanned area. However, you may narrow down the decoding area to prevent reading the wrong barcode when a number of barcodes are printed closely. The scanner will only read barcodes that appear in the effective decoding area.

Read the label "Centering On" and specify the percentage to narrow down the decoding area. For example, read "Left 10%" and then "Right 30%" for the scanner to decode barcode "A" only.

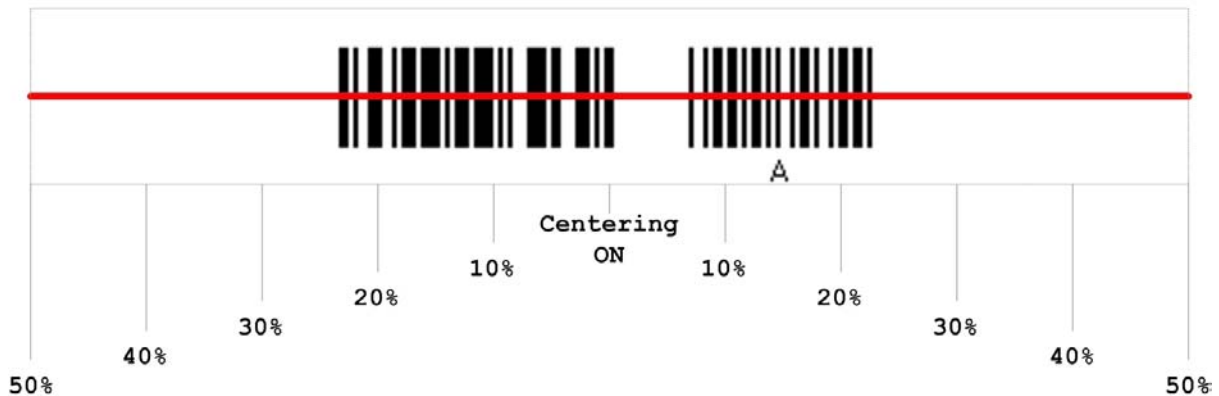

1.9.1 POSITIONING WINDOW

Centering On



*Centering Off



1.9.2 ADJUSTING WINDOW

Percentage for Left Half

*Left 50%





Percentage for Right Half



1.10 AUTO-SENSE MODE

This mode is only available when you want to seat the 1500 scanner in the Auto-Sense Stand. When you enable this mode, it will force the scanner to apply Laser mode as the scan mode. However, it works slightly different from the original Laser mode. Now the scanner will be scanning as long as it is seated in the Auto-Sense Stand, as shown below. Whenever a barcode is brought within range, the scanner will be able to decode it.

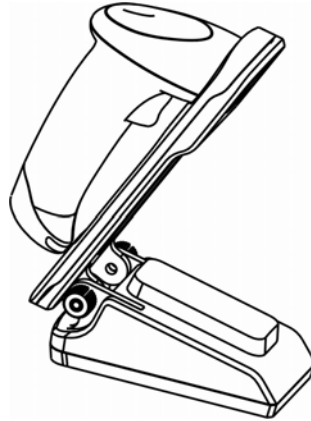

Warning: When you disable this mode later, the scan mode remains unchanged. If Laser mode is not desired, proceed to select a scan mode best suits your application.



When the ambient light is too dim to activate the sensor, you may have the scanner read the "High Sensitivity" label to improve performance.



1.11 NEGATIVE BARCODES

Normally, barcodes are printed with the color of the bars darker than that of the spaces. But for negative barcodes, they are printed in the opposite sense just like negative films. The spaces of negative barcodes are printed with a color darker than that of the bars. You can configure the scanner to be able to read negative barcodes.



1.12 SYMBOLOGIES SUPPORTED

Most of the popular barcode symbologies are supported, as listed below. Each can be individually enabled or disabled. The scanner will automatically discriminate and recognize all the symbologies that are enabled. Refer to [Chapter 3 Changing Symbology Settings](#) for details of each symbology.

Symbologies Supported: Enable/Disable		CCD Scan Engine
Codabar		Enabled
Code 93		Enabled
MSI		Disabled
Plessey		Disabled
Telepen		Disabled
Code 128	Code 128	Enabled
	EAN-128	Disabled
	ISBT-128	Disabled
Code 2 of 5	Industrial 25	Enabled
	Interleaved 25	Enabled
	Matrix 25	Disabled
Code 3 of 9	Code 39	Enabled
	Italian Pharmacode	Disabled
	French Pharmacode	Disabled



EAN/UPC	EAN-8	Enabled
	EAN-8 Addon 2	Disabled
	EAN-8 Addon 5	Disabled
	EAN-13	Enabled
	EAN-13 & UPC-A Addon 2	Disabled
	EAN-13 & UPC-A Addon 5	Disabled
	ISBN	Disabled
	UPC-E0	Enabled
	UPC-E1	Disabled
	UPC-E Addon 2	Disabled
	UPC-E Addon 5	Disabled
	UPC-A	Enabled
RSS	RSS-14	Disabled
	RSS Limited	Disabled
	RSS Expanded	Disabled

1.12.1 READ REDUNDANCY FOR ALL SYMBLOGIES

Select the level of reading security. For example,

- ▶ If "No Redundancy" is selected, one successful decoding will make the reading valid and induce the "READER Event".
- ▶ If "Three Times" is selected, it will take a total of four consecutive successful decodings of the same barcode to make the reading valid. The higher the reading security is (that is, the more redundancy the user selects), the slower the reading speed gets.

It is obvious that the more redundancy you select, the higher the reading security is, and thus, the slower the reading speed becomes. You will have to compromise between reading security and decoding speed.

*No Redundancy



One Time



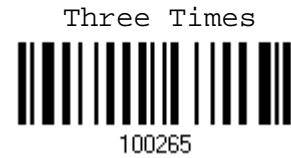
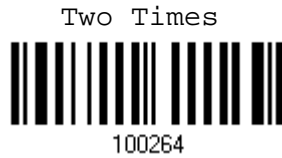

1.12.2 ADDON SECURITY FOR UPC/EAN BARCODES

You may like to enforce read redundancy (0~30 times) on UPC/EAN barcodes with addons only.

Note: UPC/EAN Addon 2 and Addon 5 must be enabled individually for this setting to take effect.

Addon Security Level (*0 ~ 30)



- 1) Read the label above to specify the read redundancy when missing add-ons while scanning UPC/EAN barcodes. (It is set to 0 by default.)
- 2) Read the "[Decimal Value](#)" label on page 135. For example, read "1" and "2" for the scanner to re-read the barcode for 12 times.
- 3) Read the "Validate" label on the same page to complete this setting.



SELECTING OUTPUT INTERFACE

In order to establish a proper connection between your computer and the scanner, we suggest that you follow these instructions –

- 1) Turn off your computer or laptop.
- 2) Connect the interface cable between the 1500 scanner and your computer.
If using the RS-232 cable, join the power supply cord.
 - ▶ If you are connecting the scanner to the USB port of the host computer via USB HID cable (part # 307), refer to [2.1 Keyboard Wedge](#) for related settings.
 - ▶ If you are connecting the scanner to the USB port of the host computer via USB Virtual COM cable (part # 308), refer to [2.2 RS-232](#) related settings.
 - ▶ If you are connecting the scanner to the IBM POS 4683/4694 via the converter cable (part # 346), refer to [2.1 Keyboard Wedge](#) for related settings.
- 3) Turn on your computer or laptop.
- 4) Have the scanner read the “Enter Setup” label to enter the configuration mode.
- 5) Have the scanner read the associated label to activate the desired interface.
See the following sections for output interfaces supported.
- 6) Have the scanner read the labels for related settings.
- 7) Have the scanner read the “Update” label to exit the configuration mode.

Note: By default, the output interface is set to “Keyboard Wedge” for 1500.



Insert a pin and press it hard to release the interface cable.

IN THIS CHAPTER

2.1 Keyboard Wedge	32
2.2 RS-232	40
2.3 Wand Emulation	45



2.1 KEYBOARD WEDGE

The Y cable allows you to connect the scanner to the keyboard input port of PC and you may join the keyboard as well. The scanned data will be transmitted to the host keyboard port as if it is manually entered via the keyboard.

Keyboard Wedge Settings	Defaults
Keyboard Type	PCAT (US)
Alphabets Layout	Normal
Digits Layout	Normal
Capital Lock Type	Normal
Capital Lock State	Off
Alphabets Transmission	Case-sensitive
Digits Transmission	Alphanumeric keypad
Alternate Composing	No
Inter-Character Delay	0 (ms)
Inter-Function Delay	0 (ms)
Send "NR" to Host	Disable
Laptop Support	Disable

2.1.1 ACTIVATE KEYBOARD WEDGE & SELECT KEYBOARD TYPE

When Keyboard Wedge interface is activated, you will have to select a keyboard type to complete this setting.

Activate & Select Keyboard Type ...



100000

- 1) Read this label above to activate Keyboard Wedge and select a keyboard type.
- 2) Read the "[Decimal Value](#)" label on page 135. Refer to the table below for the number of desired keyboard type.
- 3) Read the "Validate" label on the same page to complete this setting.



Keyboard Type

By default, the keyboard type is set to PCAT (US). The following keyboard types are supported –

No.	Keyboard Type	No.	Keyboard Type
1	PCAT (US)	16	PS55 001-2
2	PCAT (French)	17	PS55 001-82
3	PCAT (German)	18	PS55 001-3
4	PCAT (Italian)	19	PS55 001-8A
5	PCAT (Swedish)	20	PS55 002-1, 003-1
6	PCAT (Norwegian)	21	PS55 002-81, 003-81
7	PCAT (UK)	22	PS55 002-2, 003-2
8	PCAT (Belgium)	23	PS55 002-82, 003-82
9	PCAT (Spanish)	24	PS55 002-3, 003-3
10	PCAT (Portuguese)	25	PS55 002-8A, 003-8A
11	PS55 A01-1	26	IBM 3477 Type 4 (Japanese)
12	PS55 A01-2 (Japanese)	27	PS2-30
13	PS55 A01-3	28	IBM 34XX/319X, Memorex Telex 122 Keys
14	PS55 001-1	29	User-defined table
15	PS55 001-81		

2.1.2 KEYBOARD SETTINGS

Alphabets Layout

By default, the alphabets layout is set to normal mode, also known as the standard English layout. Select French or German keyboard layout if necessary. The scanner will make adjustments when sending the "A", "Q", "W", "Z", "Y", and "M" characters according to this setting.

*Normal



AZERTY



QWERTZ



US Keyboard Style – Normal

QWERTY layout, which is normally used in western countries.

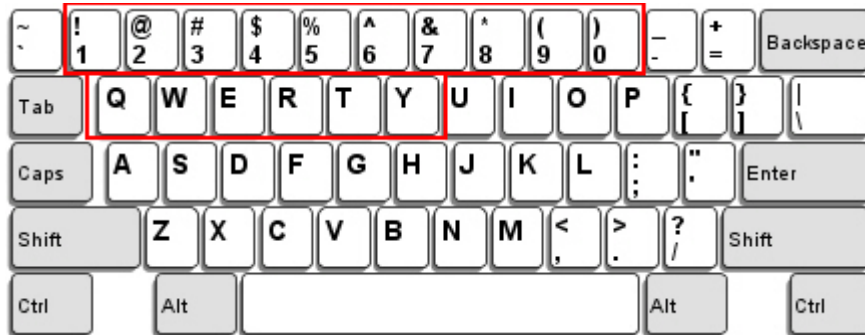

- ▶ Select “Lower Row” for the “Digits Layout” setting for the upper row is for special characters.

French Keyboard Style – AZERTY

French layout; see below for French Keyboard Style.

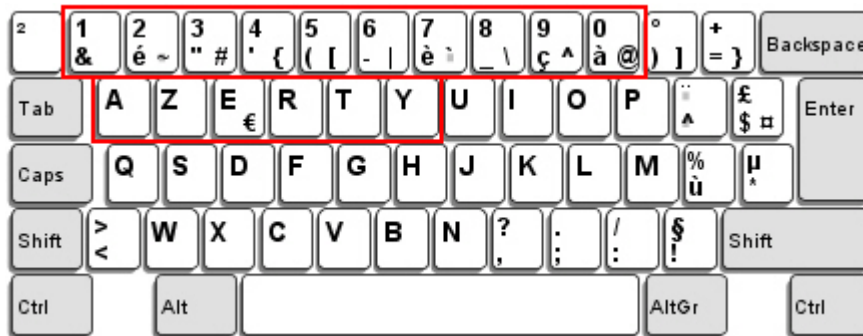

- ▶ Select “Upper Row” for the “Digits Layout” setting for the lower row is for special characters.

German Keyboard Layout – QWERTZ

German layout; see below for German Keyboard Style.

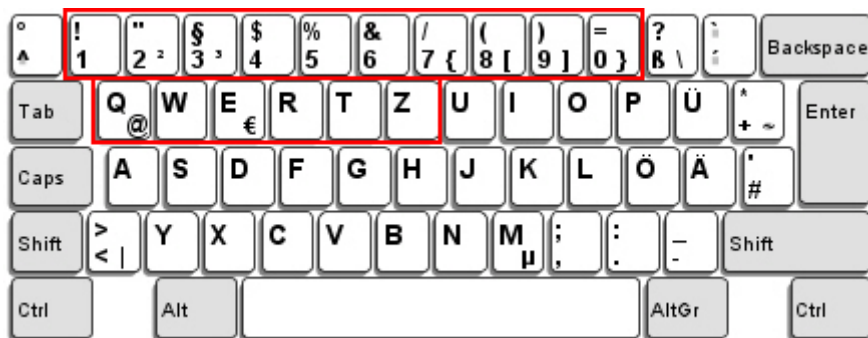

- ▶ Select “Lower Row” for the “Digits Layout” setting for the upper row is for special characters.



Note: This setting only works when the keyboard type selected is US keyboard, such as PCAT (US). The Alphabets Layout and Digits Layout setting must match your keyboard.

Digits Layout

Select a proper layout that matches the alphabets layout. The scanner will make adjustments according to this setting.

Options	Description
<i>Normal</i>	Depends on the [Shift] key or [Shift Lock] setting
<i>Lower Row</i>	For QWERTY or QWERTZ keyboard
<i>Upper Row</i>	For AZERTY keyboard

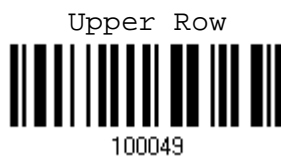

Note: This setting is meant to be used with the Alphabets Layout; and perhaps with the Character Substitution setting when support to certain keyboard types (languages) is unavailable but required.

Capital Lock Type & Setting

In order to send the alphabets with correct case, the scanner needs to know the status of Caps Lock on the keyboard. Incorrect settings may result in reversed case of the alphabets being transmitted.

Cap Lock Type	Description
Normal	Normal type
Capital Lock	When enabled, the keys of alphabetic characters will be interpreted as capital letters. However, this does not affect the number or punctuation keys.
Shift Lock	When enabled, the keys of alphabetic characters will be interpreted as capital letters. In addition, this affects the number or punctuation keys.



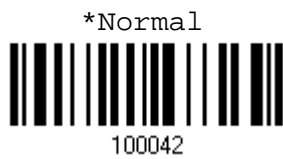

Capital Lock State	Description
Capital Lock OFF	Assuming that the status of Caps Lock on the keyboard is OFF, transmitted characters are exactly the same as in the barcode (when "case-sensitive" is selected for Alphabets Transmission).
Capital Lock ON	Assuming that the status of Caps Lock on the keyboard is ON, transmitted characters are exactly the same as in the barcode (when "case-sensitive" is selected for Alphabets Transmission). ▶ Refer to the Capital Lock Type above.
Auto Detection	The scanner will automatically detect the status of Caps Lock on the keyboard before data is transmitted; transmitted characters are exactly the same as in the barcode (when "case-sensitive" is selected for Alphabets Transmission). ▶ This setting is not supported on PDAs.



Alphabets Transmission

By default, the alphabets transmission is case-sensitive, meaning that the alphabets will be transmitted according to their original case, the status of Caps Lock on the keyboard, as well as the Capital Lock setting. Select [Ignore Case] to have alphabets transmitted according to the status of Caps Lock on the keyboard only.

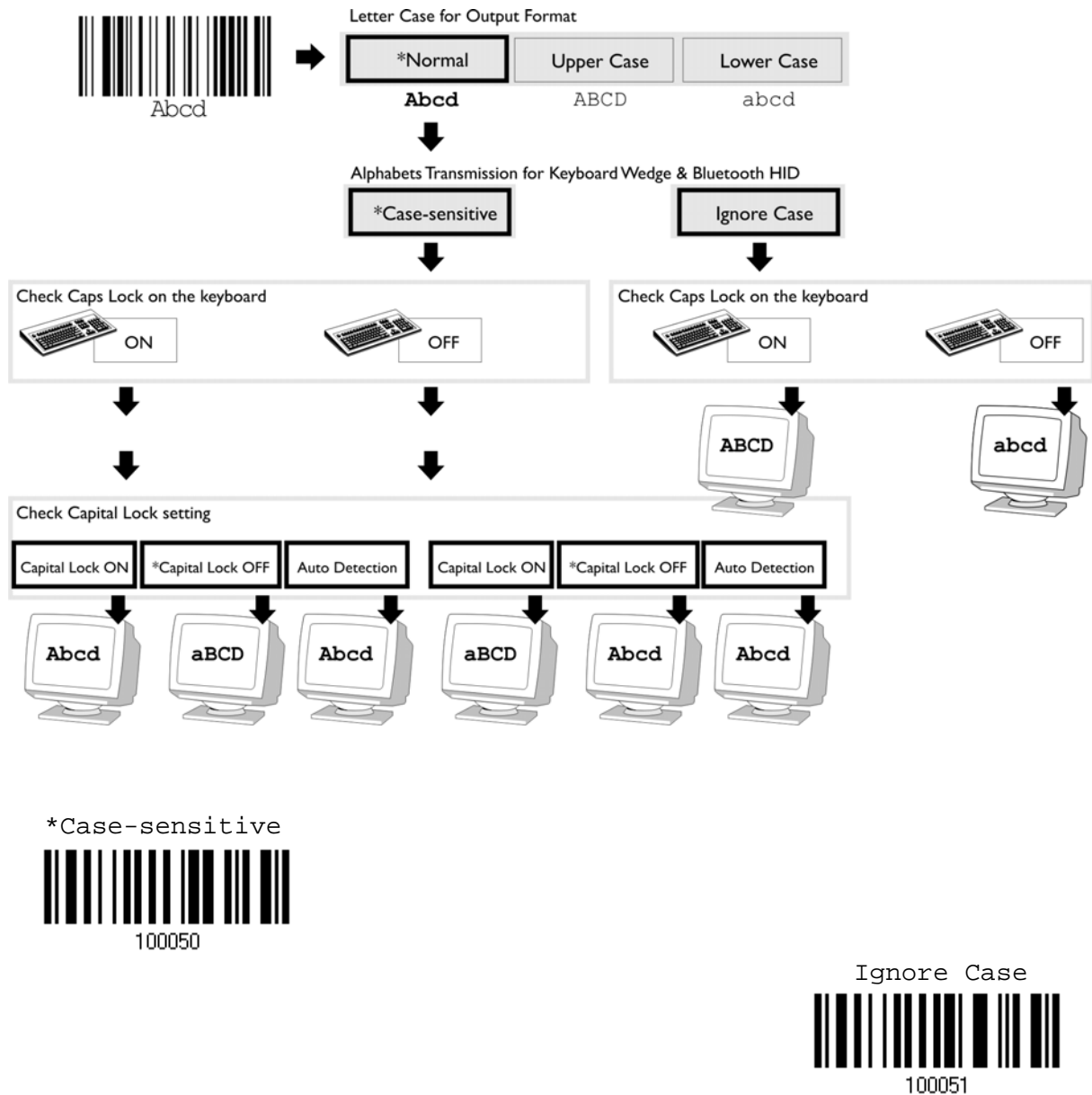

Digits Transmission

By default, the alphanumeric keypad is used for transmitting digits. Select "Numeric Keypad" if you wish to use the keys on the numeric keypad.



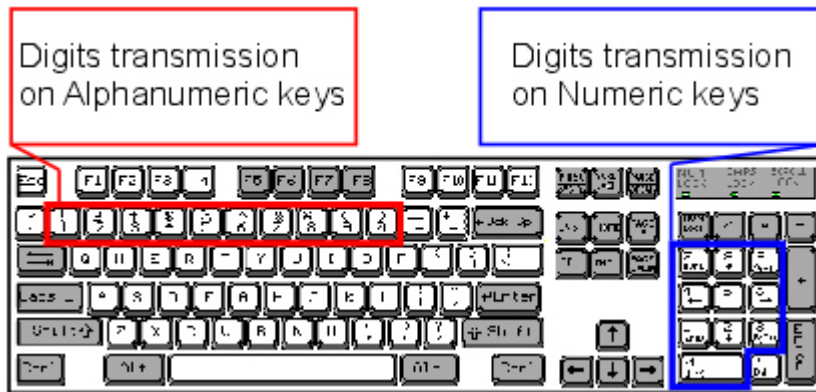

*Alphanumeric Key



Numeric Key



Note: If you select "Numeric Keypad", the Num Lock status of the physical keyboard should be "ON". This setting is not supported on PDAs.

ALT Composing

By default, Alternate key composing is disabled. Select [Yes] to allow emulating Alternate key code of a specific keyboard character. For example, [Alt] + [065] will be sent to host for the character "A" regardless the keyboard type you are using.

Yes



*No



Laptop Support

By default, laptop support is disabled. It is suggested to enable this feature if you connect the wedge cable to a laptop without an external keyboard being inter-connected.





2.1.3 INTER-CHARACTER DELAY

By default, the inter-character delay is set to zero. Specify a value, ranging from 0 to 254 in units of millisecond, to match the computer response time of the keyboard interface. Such delay time is inserted between every character being transmitted. The longer the delay time is, the slower the transmission speed will be.

Inter-Character Delay ... (*0 ~ 254)



- 1) Read the label above to specify the inter-character delay.
- 2) Read the "[Decimal Value](#)" label on page 135 for the desired inter-character delay (millisecond).
- 3) Read the "Validate" label on the same page to complete this setting.

2.1.4 INTER-FUNCTION DELAY

By default, the inter-function delay is set to zero. Specify a value, ranging from 0 to 254 in units of millisecond, to match the computer response time of the keyboard interface. Such delay time is inserted between every function code (0x01 ~ 0x1F) being transmitted. The longer the delay time is, the slower the transmission speed will be.

Inter-Function Delay ... (*0 ~ 254)



- 1) Read the label above to specify the inter-function delay.
- 2) Read the "[Decimal Value](#)" label on page 135 for the desired inter-function delay (millisecond).
- 3) Read the "Validate" label on the same page to complete this setting.



2.2 RS-232

Use the RS-232 cable to connect the scanner to the serial port of PC and join the power adaptor to the RS-232 connector. The associated RS-232 parameters must match those configured on the computer. The scanned data will be transmitted to the serial port.

RS-232 Settings	Defaults
Baud Rate, Data Bit, Parity, Stop Bit	9600 bps, 8 bits, No parity, 1 stop bit
Flow Control	None
Inter-Character Delay	0 (ms)
Inter-Function Delay	0 (ms)
Send "NR" to Host	Disable
ACK/NAK Timeout	0
ACK/NAK Beep	Disable

2.2.1 ACTIVATE RS-232 INTERFACE

Activate RS-232 Interface



2.2.2 BAUD RATE

115200 bps



57600 bps



38400 bps



19200 bps





2.2.3 DATA BITS



2.2.4 PARITY

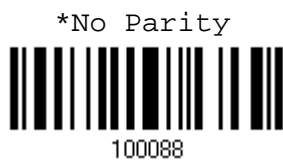



2.2.5 STOP BIT



2.2.6 FLOW CONTROL

By default, there is no flow control in use. Select the flow control (handshake) method.

Options	Description
No	No flow control
Scanner Ready	The scanner will activate the RTS signal upon powering on. After each good read, the scanner will then wait for the CTS signal to become active. Data will not be sent until the CTS signal becomes active.
Data Ready	The RTS signal will be activated after each good read. The scanner will then wait for the CTS signal to become active. Data will not be sent until the CTS signal becomes active.
Inverted Data Ready	It works the same as the Data Ready flow control, except that the RTS signal level is inverted.





2.2.7 INTER-CHARACTER DELAY

By default, the inter-character delay is zero. Specify a value, ranging from 0 to 254 in units of millisecond, to match the computer response time. Such delay time is inserted between every character being transmitted. The longer the delay time is, the slower the transmission speed will be.



- 1) Read the label above to specify the inter-character delay.
- 2) Read the "[Decimal Value](#)" label on page 135 for the desired inter-character delay (millisecond).
- 3) Read the "Validate" label on the same page to complete this setting.

2.2.8 INTER-FUNCTION DELAY

By default, the inter-function delay is set to zero. Specify a value, ranging from 0 to 254 in units of millisecond, to match the computer response time of the keyboard interface. Such delay time is inserted between every function code (0x01 ~ 0x1F) being transmitted. The longer the delay time is, the slower the transmission speed will be.



- 1) Read this label above to specify the inter-function delay.
- 2) Read the "[Decimal Value](#)" label on page 135 for the desired inter-function delay (millisecond).
- 3) Read the "Validate" label on the same page to complete this setting.



2.2.9 ACK/NAK TIMEOUT

By default, the scanner sends data to the host without waiting for an ACK/NAK response before sending more data. Specify a value, ranging from 1 to 99 in units of 0.1 second. If no response within the specified period of time, the scanner will attempt to send the same data three more times. If all the attempts fail without any notification, data loss will occur.

ACK/NAK Time-Out after ... (*0 ~ 99)



100013

- 1) Read the label above to specify the time interval for the scanner to send data and wait for a response from the host.
- 2) Read the "[Decimal Value](#)" label on page 135. For example, read "1" and "0" for the scanner to automatically shut down after being idle for 1 second.
- 3) Read the "Validate" label on the same page to complete this setting.

ACK/NAK Error Beep

Enable Error Beep



100015

*Disable Error Beep



100014

Note: We suggest you to enable the error beep so that you will be notified of such data loss and have the scanner re-read data.



2.3 WAND EMULATION

The wand emulation cable allows you to connect the scanner to a data terminal that is expecting input from a wand scanner.

Wand Emulation Settings	Defaults
Normal State	Low
Bar State	High
Module Time	1 (ms)
Margin Time	20 (ms)

2.3.1 ACTIVATE WAND EMULATION

Activate Wand Emulation



2.3.2 NORMAL STATE

By default, the signal level is set "Low" for the normal state when not transmitting any barcode image (= white spaces in a barcode).



2.3.3 BAR STATE

By default, the signal level is set "High" for a bar when transmitting a barcode image (= dark bars in a barcode).



Update



2.3.4 MODULE TIME

By default, it is set 1 millisecond as the time span for bar and space modules. Select other value for the module time, in units of micro-second or millisecond.



2.3.5 MARGIN TIME

By default, it is set 20 milliseconds as the time span for the change in state for bar and space modules. Select other value for the margin time.



Note: Margin Time is applied only when the signal level for Normal State and Bar State is the same.





CHANGING SYMBOLOGY SETTINGS

In this chapter, a brief on the symbology settings is provided for your reference.

IN THIS CHAPTER

3.1 Codabar	50
3.2 Code 25 - Industrial 25.....	52
3.3 Code 25 - Interleaved 25	55
3.4 Code 25 - Matrix 25	58
3.5 Code 39	61
3.6 Code 93	63
3.7 Code 128.....	63
3.8 EAN-8	64
3.9 EAN-13	66
3.10 EAN-128	68
3.11 ISBT128	69
3.12 MSI	70
3.13 French Pharmacode	73
3.14 Italian Pharmacode	74
3.15 Plessey	75
3.16 RSS Family	76
3.17 Telepen	80
3.18 UPC-A	81
3.19 UPC-E	83



3.1 CODABAR

*Enable Codabar



100313

Disable Codabar



100312

3.1.1 START/STOP CHARACTERS SELECTION

Select one of the four different start/stop character pairs –

* abcd/abcd



100436

abcd/tn*e



100437

ABCD/ABCD



100438

ABCD/TN*E



100439



3.1.2 START/STOP TRANSMISSION

Decide whether or not to include the start/stop characters in the data being transmitted.

Transmit Codabar
Start/Stop Characters



*Do Not Transmit



3.1.3 CLSI CONVERSION

When enabled, the CLSI editing strips the start/stop characters and inserts a space after the first, fifth, and tenth characters of a 14-character Codabar barcode.

Apply CLSI Editing



*Do Not Apply



Note: The 14-character barcode length does not include start/stop characters.



3.2 CODE 25 – INDUSTRIAL 25

*Enable Industrial 25



Disable Industrial 25



3.2.1 START/STOP PATTERN SELECTION

This decides the readability of all 2 of 5 symbology variants. For example, flight tickets actually use an Industrial 2 of 5 barcode but with Interleaved 2 of 5 start/stop pattern. In order to read this barcode, the start/stop pattern selection parameter of Industrial 2 of 5 should be set to "Interleaved 25".

*Industrial 25
Start/Stop Pattern



Interleaved 25
Start/Stop Pattern



Matrix 25
Start/Stop Pattern



3.2.2 CHECKSUM VERIFICATION

Decide whether to verify the checksum. If the checksum is incorrect, the barcode will not be accepted.

Verify Industrial 25
Checksum



*Do Not Verify



3.2.3 CHECKSUM TRANSMISSION

Decide whether to include the checksum in the data being transmitted.

*Transmit Industrial
25 Checksum



Do Not Transmit



3.2.4 CODE LENGTH QUALIFICATION

Because of the weak structure of the 2 of 5 symbologies, it is possible to make a "short scan" error. To prevent the "short scan" error, define the "Length Qualification" settings to ensure that the correct barcode is read by qualifying the allowable code length.

- ▶ If "Max/Min Length" is selected, the maximum length and the minimum length must be specified. It only accepts those barcodes with lengths that fall between max/min lengths specified.
- ▶ If "Fixed Length" is selected, up to 2 fixed lengths can be specified.

- 1) Read the label to enable either Max. /Min. Length qualification or Fixed Length(s) qualification.

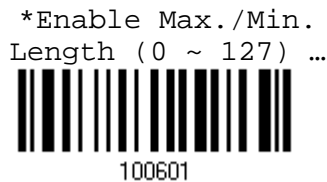

- 2) Read the label for Max. Length or Fixed Length 1, and follow steps 3~4.
Repeat steps 2~4 for Min. Length or Fixed Length 2.



- 3) Read the "[Decimal Value](#)" label on page 135 for the desired length.
- 4) Read the "Validate" label on the same page to complete this setting.



3.3 CODE 25 – INTERLEAVED 25

*Enable Interleaved 25



Disable Interleaved 25



3.3.1 START/STOP PATTERN SELECTION

This decides the readability of all 2 of 5 symbology variants. For example, flight tickets actually use an Industrial 2 of 5 barcode but with Interleaved 2 of 5 start/stop pattern. In order to read this barcode, the start/stop pattern selection parameter of Industrial 2 of 5 should be set to "Interleaved 25".

Industrial 25
Start/Stop Pattern



*Interleaved 25
Start/Stop Pattern



Matrix 25
Start/Stop Pattern



3.3.2 CHECKSUM VERIFICATION

Decide whether to verify the checksum. If the checksum is incorrect, the barcode will not be accepted.

Verify Interleaved 25

Checksum



100429

*Do Not Verify



100428

3.3.3 CHECKSUM TRANSMISSION

Decide whether to include the checksum in the data being transmitted.

*Transmit Interleaved

25 Checksum



100431

Do Not Transmit



100430



3.3.4 CODE LENGTH QUALIFICATION

Because of the weak structure of the 2 of 5 symbologies, it is possible to make a "short scan" error. To prevent the "short scan" error, define the "Length Qualification" settings to ensure that the correct barcode is read by qualifying the allowable code length.

- ▶ If "Max/Min Length" is selected, the maximum length and the minimum length must be specified. It only accepts those barcodes with lengths that fall between max/min lengths specified.
- ▶ If "Fixed Length" is selected, up to 2 fixed lengths can be specified.

- 1) Read the label to enable either Max. /Min. Length qualification or Fixed Length(s) qualification.

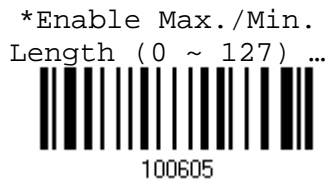

- 2) Read the label for Max. Length or Fixed Length 1, and follow steps 3~4.
Repeat steps 2~4 for Min. Length or Fixed Length 2.



- 3) Read the "[Decimal Value](#)" label on page 135 for the desired length.
- 4) Read the "Validate" label on the same page to complete this setting.



3.4 CODE 25 – MATRIX 25

Enable Matrix 25



100311

*Disable Matrix 25



100310

3.4.1 START/STOP PATTERN SELECTION

This decides the readability of all 2 of 5 symbology variants. For example, flight tickets actually use an Industrial 2 of 5 barcode but with Interleaved 2 of 5 start/stop pattern. In order to read this barcode, the start/stop pattern selection parameter of Industrial 2 of 5 should be set to "Interleaved 25".

Industrial 25
Start/Stop Pattern



100420

Interleaved 25
Start/Stop Pattern



100421

*Matrix 25
Start/Stop Pattern



100422



3.4.2 CHECKSUM VERIFICATION

Decide whether to verify the checksum. If the checksum is incorrect, the barcode will not be accepted.



3.4.3 CHECKSUM TRANSMISSION

Decide whether to include the checksum in the data being transmitted.



3.4.4 CODE LENGTH QUALIFICATION

Because of the weak structure of the 2 of 5 symbologies, it is possible to make a "short scan" error. To prevent the "short scan" error, define the "Length Qualification" settings to ensure that the correct barcode is read by qualifying the allowable code length.

- ▶ If "Max/Min Length" is selected, the maximum length and the minimum length must be specified. It only accepts those barcodes with lengths that fall between max/min lengths specified.
- ▶ If "Fixed Length" is selected, up to 2 fixed lengths can be specified.

- 1) Read the label to enable either Max. /Min. Length qualification or Fixed Length(s) qualification.

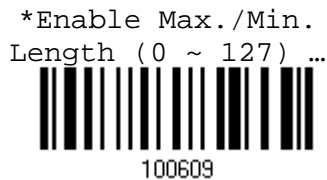

- 2) Read the label for Max. Length or Fixed Length 1, and follow steps 3~4.
Repeat steps 2~4 for Min. Length or Fixed Length 2.



- 3) Read the "[Decimal Value](#)" label on page 135 for the desired length.
- 4) Read the "Validate" label on the same page to complete this setting.



3.5 CODE 39

*Enable Code 39



Disable Code 39



3.5.1 START/STOP TRANSMISSION

Decide whether or not to include the start/stop characters in the data being transmitted.

Transmit Code 39
Start/Stop Characters



*Do Not Transmit



3.5.2 CHECKSUM VERIFICATION

Decide whether or not to perform checksum verification when decoding barcodes.

- ▶ If enabled and the checksum found incorrect, the barcode will not be accepted.

Verify Code 39 Checksum



*Do Not Verify



3.5.3 CHECKSUM TRANSMISSION

Decide whether or not to include the checksum character in the data being transmitted.

*Transmit Code 39
Checksum



Do Not Transmit



3.5.4 STANDARD/FULL ASCII CODE 39

Decide whether or not to support Code 39 Full ASCII that includes all the alphanumeric and special characters.

Code 39 Full ASCII



*Standard Code 39



3.6 CODE 93

You can only configure the scanner to read this symbology or not.

*Enable Code 93



Disable Code 93



3.7 CODE 128

You can only configure the scanner to read this symbology or not.

*Enable Code 128



Disable Code 128



3.8 EAN-8

*Enable EAN-8
(No Addon)



Disable EAN-8
(No Addon)



Enable EAN-8
Addon 2



*Disable EAN-8
Addon 2



Enable EAN-8
Addon 5



*Disable EAN-8
Addon 5



3.8.1 CONVERT TO EAN-13

Decide whether or not to expand the read EAN-8 barcode into EAN-13.

- ▶ If enabled, the next processing will follow the parameters configured for EAN-13.

Convert EAN-8
to EAN-13



*Do Not Convert



3.8.2 CHECKSUM TRANSMISSION

Decide whether or not to include the checksum character in the data being transmitted.

*Transmit EAN-8
Checksum



Do Not Transmit



3.9 EAN-13

*Enable EAN-13
(No Addon)



Disable EAN-13
(No Addon)



Enable EAN-13
Addon 2



*Disable EAN-13
Addon 2



Enable EAN-13
Addon 5



*Disable EAN-13
Addon 5



3.9.1 ISBN CONVERSION

Decide whether or not to convert the EAN-13 barcode, starting with 978 and 979, to ISBN.

Convert EAN-13 to ISBN



*Do Not Convert



3.9.2 ISSN CONVERSION

Decide whether or not to convert the EAN-13 barcode, starting with 977 to ISSN.

Convert EAN-13 to ISSN



*Do Not Convert



3.9.3 CHECKSUM TRANSMISSION

Decide whether or not to include the checksum character in the data being transmitted.

*Transmit EAN-13
Checksum



Do Not Transmit



3.10 EAN-128

Enable EAN-128



100319

*Disable EAN-128



100318

3.10.1 CODE ID TRANSMISSION

Decide whether or not to include the Code ID ("1C1") in the data being transmitted.

Transmit EAN-128
Code ID



100519

*Do Not Transmit



100518

3.10.2 FIELD SEPARATOR (GS CHARACTER)

Decide whether or not to apply a field separator (to convert the FNC1 control character to human readable character).

Enable Field Separator ...



100616

- 1) Read the label above to enable field separator.
- 2) Read the "[Hexadecimal Value](#)" label on page 136 for the desired character string.
- 3) Read the "Validate" label to complete this setting.



Note: EAN-128 barcodes start with the FNC1 control character to distinguish themselves from other uses of Code 128. FNC1 is also used to separate data fields in the EAN-128 barcodes.

3.11 ISBT 128

You can only configure the scanner to read this symbology or not.

Enable ISBT 128



100355

*Disable ISBT 128



100354



3.12 MSI



3.12.1 CHECKSUM VERIFICATION

Select one of the three checksum calculations to perform checksum verification when decoding barcodes.

- ▶ If enabled and the checksum found incorrect, the barcode will not be accepted.

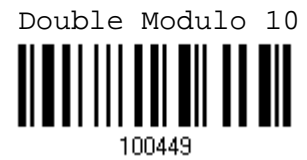

3.12.2 CHECKSUM TRANSMISSION

Decide whether or not to include the checksum character in the data being transmitted.

*Last Digit Not
Transmitted



100452

Both Digits
Transmitted



100453

Both Digits Not
Transmitted



100454



3.12.3 CODE LENGTH QUALIFICATION

Because of the weak structure of the symbology, it is possible to make a "short scan" error. To prevent the "short scan" error, define the "Length Qualification" settings to ensure that the correct barcode is read by qualifying the allowable code length.

- ▶ If "Max/Min Length" is selected, the maximum length and the minimum length must be specified. It only accepts those barcodes with lengths that fall between max/min lengths specified.
- ▶ If "Fixed Length" is selected, up to 2 fixed lengths can be specified.

- 1) Read the label to enable either Max. /Min. Length qualification or Fixed Length(s) qualification.

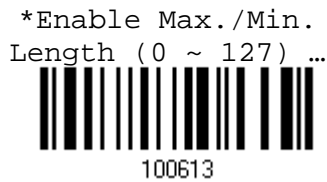

- 2) Read the label for Max. Length or Fixed Length 1, and follow steps 3~4.
Repeat steps 2~4 for Min. Length or Fixed Length 2.



- 3) Read the "[Decimal Value](#)" label on page 135 for the desired length.
- 4) Read the "Validate" label on the same page to complete this setting.



3.13 FRENCH PHARMACODE

Enable French Pharmacode



100305

*Disable French
Pharmacode



100304

3.13.1 CHECKSUM TRANSMISSION

Decide whether or not to include the checksum character in the data being transmitted.

*Transmit French
Pharmacode Checksum



100411

Do Not Transmit



100410



3.14 ITALIAN PHARMACODE

Enable Italian Pharmacode



100303

*Disable Italian
Pharmacode

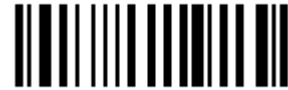

100302

3.14.1 CHECKSUM TRANSMISSION

Decide whether or not to include the checksum character in the data being transmitted.

*Transmit Italian
Pharmacode Checksum



100409

Do Not Transmit



100408



3.15 PLESSEY

Enable Plessey



*Disable Plessey



3.15.1 CONVERT TO UK PLESSEY

Decide whether or not to change each occurrence of the character 'A' to character 'X' in the decoded data.

Convert to UK Plessey



*Do Not Convert



3.15.2 CHECKSUM TRANSMISSION

Decide whether or not to include the checksum characters (two digits) in the data being transmitted.

*Transmit Plessey
Checksum



Do Not Transmit



3.16 RSS FAMILY

3.16.1 CODE ID SELECTION

Select a desired Code ID to use – RSS Code ID “]e0” or EAN-128 Code ID “]C1”.

“]C1” for RSS Code ID



“]e0” for RSS Code ID
(Default)



3.16.2 RSS-14

Enable RSS-14 &
RSS Expanded



*Disable RSS-14 &
RSS Expanded



Code ID Transmission

Decide whether or not to include the Code ID in the data being transmitted.

*Transmit RSS-14 Code ID



Do Not Transmit



Application ID Transmission

Decide whether or not to include the Application ID ("01") in the data being transmitted.

*Transmit RSS-14
Application ID



Do Not Transmit



Checksum Transmission

Decide whether or not to include the check digit in the data being transmitted.

*Transmit RSS-14
Checksum



Do Not Transmit



3.16.3 RSS EXPANDED

Enable RSS-14 &
RSS Expanded



*Disable RSS-14 &
RSS Expanded



Code ID Transmission

Decide whether or not to include the Code ID in the data being transmitted.



3.16.4 RSS LIMITED



Code ID Transmission

Decide whether or not to include the Code ID in the data being transmitted.



Application ID Transmission

Decide whether or not to include the Application ID ("01") in the data being transmitted.

*Transmit RSS Limited
Application ID



Do Not Transmit



Checksum Transmission

Decide whether or not to include the check digit in the data being transmitted.

*Transmit RSS
Limited Checksum



Do Not Transmit



3.17 TELEPEN

Enable Telepen



100353

*Disable Telepen



100352

3.17.1 TELEPEN OUTPUT – FULL ASCII/NUMERIC

Decide whether or not to support Telepen in full ASCII code. By default, it supports ASCII mode.

- ▶ AIM Telepen (Full ASCII) includes all the alphanumeric and special characters.

Original Telepen
(Numeric)



100485

* AIM Telepen



100484



3.18 UPC-A

*Enable UPC-A
(No Addon)



Disable UPC-A
(No Addon)



Enable UPC-A
Addon 2



*Disable UPC-A
Addon 2



Enable UPC-A
Addon 5



*Disable UPC-A
Addon 5



3.18.1 CONVERT TO EAN-13

Decide whether or not to expand the read UPC-A barcode into EAN-13.

- ▶ If enabled, the next processing will follow the parameters configured for EAN-13.

Convert UPC-A
to EAN-13



*Do Not Convert



3.18.2 SYSTEM NUMBER TRANSMISSION

Decide whether or not to include the system number in the data being transmitted.

*Transmit UPC-A
System Number



Do Not Transmit



3.18.3 CHECKSUM TRANSMISSION

Decide whether or not to include the checksum character in the data being transmitted.

*Transmit UPC-A
Checksum



Do Not Transmit



3.19 UPC-E

*Enable UPC-E
(No Addon)



Disable UPC-E
(No Addon)



Enable UPC-E
Addon 2



*Disable UPC-E
Addon 2



Enable UPC-E
Addon 5



*Disable UPC-E
Addon 5



3.19.1 SYSTEM NUMBER SELECTION

Decide whether to decode the ordinary UPC-E barcodes only or both UPC-E0 and UPC-E1 barcodes.

- ▶ System number 0 enabled for decoding UPC-E0 barcodes.
- ▶ System number 1 enabled for decoding UPC-E1 barcodes.

System Number 0 & 1



* System Number 0 Only



Warning: Because of the way system number 1 is encoded, if both system numbers are enabled, the user might suffer from short scanning UPC-A or EAN-13 barcodes into UPC-E1 barcodes.

3.19.2 CONVERT TO UPC-A

Decide whether or not to expand the read UPC-E barcode into UPC-A.

- ▶ If enable, the next processing will follow the parameters configured for UPC-A.

Convert UPC-E
to UPC-A



*Do Not Convert



3.19.3 SYSTEM NUMBER TRANSMISSION

Decide whether or not to include the system number in the data being transmitted.

Transmit UPC-E
System Number



*Do Not Transmit



3.19.4 CHECKSUM TRANSMISSION

Decide whether or not to include the checksum character in the data being transmitted.

*Transmit UPC-E
Checksum



Do Not Transmit





DEFINING OUTPUT FORMAT

You may configure in which format the collected data will be output to the host computer. Barcode read by the scanner will be processed in the following sequence –

- 1) Perform character substitution on the data scanned.
- 2) Add [Code ID](#) and [Length Code](#) to the front of the data: [Code ID][LengthCode][Data]
- 3) Process the whole data in step 2 with user formats. Data is now divided into fields by user specified rules. Refer to [Chapter 5 Applying Formats for Data Editing](#).
- 4) Add [Prefix Code](#) and [Suffix Code](#) before transmission: [Prefix Code][Processed Data][Suffix Code]

IN THIS CHAPTER

4.1 Letter Case	87
4.2 Character Substitution	88
4.3 Prefix/Suffix Code	94
4.4 Code ID	95
4.5 Length Code	99
4.6 Multi-Barcode Editor	102

4.1 LETTER CASE

By default, the alphabets transmission is case-sensitive, meaning that the alphabets will be transmitted according to their original case. Ignoring the original letter case, select [Upper Case] to output data in upper case only; otherwise, select [Lower Case] to output data in lower case only.

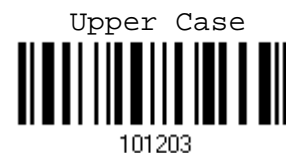

4.2 CHARACTER SUBSTITUTION

Character substitution is performed on every occurrence of the first character specified. If only one character is specified, every occurrence of that character in the barcode will be taken away.

- ▶ The first character will be replaced by the second character(s).
- ▶ Up to three sets of character substitution can be configured.

Note: The character substitution is performed only on the barcode itself and before the processing of editing formats. It is not applicable to the Prefix/Suffix Code, Code ID, Length Code, or any Additional Field.

4.2.1 SELECT A SET FOR CHARACTER SUBSTITUTION

Configure Set 1



Configure Set 2



Configure Set 3



- 1) Read the label above to enable character substitution by set.

For example, have the scanner read the "Set 1" label to configure the first set of character substitution. The scanner will respond with one short beep, high tone, to indicate more setup labels are required.

- 2) Read the "[Hexadecimal Value](#)" label on page 136 for the desired character string.

For example, have the scanner read (1) "3", "0", "2" and "D" to replace the character [0] with a dash [-] for Set 1, and (2) "3", "0", "2", "D", "3" and "0" to replace the character [0] with a dash [- 0] for Set 2.

- 3) Read the "Validate" label to complete this setting. (The defined set or sets will be applied to all symbologies by default.)



4.2.2 SYMBOLOGIES FOR CHARACTER SUBSTITUTION (ALL 3 SETS)

By default character substitution will be performed on all symbologies. If the character substitution is not desired with one or more symbologies, read the “Do Not Apply” label for each undesired symbologies and all the three sets will be ignored for them.

Character Substitution for Codabar



Character Substitution for Code 39



Character Substitution for Code 93



Character Substitution for Code 128



Character Substitution for EAN-128



Character Substitution for EAN-8 (No Addon)



Character Substitution for EAN-8 Addon 2



Character Substitution for EAN-8 Addon 5



Character Substitution for EAN-13 (No Addon)



Character Substitution for EAN-13 Addon 2



Character Substitution for EAN-13 Addon 5



Character Substitution for French Pharmacode



Character Substitution for Italian Pharmacode



Character Substitution for Industrial 25



Character Substitution for Interleaved 25



Character Substitution for Matrix 25



Character Substitution for MSI



Character Substitution for Plessey



Character Substitution for RSS Family



Character Substitution for Telepen



Character Substitution for UPC-A (No Addon)



Character Substitution for UPC-A Addon 2



Character Substitution for UPC-A Addon 5



Character Substitution for UPC-E (No Addon)



Character Substitution for UPC-E Addon 2



Character Substitution for UPC-E Addon 5



4.3 PREFIX/SUFFIX CODE

By default, there is no prefix code, and [ENTER] or [CR] (Carriage Return) is configured to be suffix code. Up to 8 characters can be configured, for example, "Barcode_", and you will have the string appear in front of the barcode read, like this – "Barcode_1234567890".

- ▶ If "Keyboard Wedge" is configured for interface, [Key Type](#) and [Key Status](#) will then become applicable. You may decide whether or not to apply Key Status when "Normal Key" is selected for Key Type.

Key Type		Key Status
Scan Code	Up to 4 scan code values are allowed.	N/A
Normal Key	Up to 8 character strings are allowed. ▶ Default setting	<ul style="list-style-type: none"> ▶ Add Shift ▶ Add Left Ctrl ▶ Add Left Alt ▶ Add Right Ctrl ▶ Add Right Alt ▶ Add Break For example, read labels for [Add Shift], [A], [Add Shift], and [B].

Configure Prefix



Configure Suffix



- 1) Read the label above to apply prefix code or suffix code separately, and follow steps 2~3. (Max. 8 characters each)
- 2) Read the "[Hexadecimal Value](#)" label on page 136 for the desired character string. For example, read "2" and "B" for the scanner to prefix or suffix the character [+].
- 3) Read the "Validate" label to complete this setting.



4.4 CODE ID

Up to two characters for Code ID can be configured for each symbology. To make the Code ID configuration easier, the scanner provides five pre-defined Code ID sets that you can select one and make necessary changes on it.

- ▶ If "Keyboard Wedge" is configured for interface, [Key Type](#) and [Key Status](#) will then become applicable. You may decide whether or not to apply Key Status when "Normal Key" is selected for Key Type.

Key Type		Key Status
Scan Code	Up to 1 scan code values are allowed.	N/A
Normal Key	Up to 2 character strings are allowed. <ul style="list-style-type: none"> ▶ Default setting 	<ul style="list-style-type: none"> ▶ Add Shift ▶ Add Left Ctrl ▶ Add Left Alt ▶ Add Right Ctrl ▶ Add Right Alt ▶ Add Break For example, read labels for [Add Shift] and the character [A].

Note: "]C1" is the Code ID of EAN-128 barcodes; "]e0" is the default Code ID of RSS barcodes.

4.4.1 SELECT PRE-DEFINED CODE ID

Code ID options	Set 1	Set 2	Set 3	Set 4	Set 5
Code 39	A	C	Y	M	A
Italian Pharmacode	A	C	Y	M	A
French Pharmacode	A	C	Y	M	A
Industrial 25	C	H	H	H	S
Interleaved 25	D	I	Z	I	S
Matrix 25	E	G	G	G	S
Codabar	F	N	X	N	F
Code 93	I	L	L	L	G
Code 128	H	K	K	K	C
UPC-E	S	E	C	E	E
EAN-8	P	B	B	FF	E
EAN-13	M	A	A	F	E



UPC-A	J	A	A	A	E
MSI	V	V	D	P	M
Plessey	W	W	E	Q	P
Telepen	Z	---	---	---	---

Apply Code ID Set 1



Apply Code ID Set 2



Apply Code ID Set 3



Apply Code ID Set 4



Apply Code ID Set 5



4.4.2 CHANGE CODE ID

- 1) Read the label of a specific symbology below to change its code ID.
- 2) Read the ["Hexadecimal Value"](#) label on page 136 for the desired character string. For example, read "4" and "4" for applying the character [D] for Code ID.
- 3) Read the "Validate" label to complete this setting.



Configure Code ID
for Codabar



101456

Configure Code ID
for Code 39



101450

Configure Code ID
for Code 93



101457

Configure Code ID
for Code 128



101458

Configure Code ID
for EAN-8



101460

Configure Code ID
for EAN-13



101461

Configure Code ID for
French Pharmacode



101452

Configure Code ID for
Italian Pharmacode



101451

Configure Code ID
for Industrial 25



101453

Configure Code ID
for Interleaved 25



101454



Configure Code ID
for Matrix 25



Configure Code ID
for MSI



Configure Code ID
for Plessey



Configure Code ID
for Telepen



Configure Code ID
for UPC-A



Configure Code ID
for UPC-E



4.4.3 CLEAR CODE ID SETTINGS

Clear All Code ID Settings



4.5 LENGTH CODE

A two-digit code representing the length of barcode data (character count) can be inserted in front of data being transmitted. Such "Length" code can be individually enabled or disabled for each symbology.

Length Code for Codabar



Length Code for Code 39



Length Code for Code 93



Length Code for Code 128



Length Code for EAN-128 & RSS



Length Code for EAN-8



Length Code for EAN-13



Length Code for French Pharmacode



Length Code for Italian Pharmacode



Length Code for Industrial 25



Length Code for Interleaved 25



Length Code for Matrix 25



Length Code for MSI



Length Code for Plessey



Length Code for Telepen



Length Code for UPC-A



Length Code for UPC-E



4.6 MULTI-BARCODE EDITOR

The Multi-Barcode Editor allows you to decide the output sequence of a concatenation of barcodes. Up to five barcodes can be specified. When you enable this mode, it will force the scanner to apply Laser mode as the scan mode.

Note: The Multi-Barcode Editor has nothing to do with [Multi-Barcode Mode](#).

The barcodes that are found meeting the specified criteria below will be arranged in the desired sequence.

- ▶ Code Type
- ▶ 4-digit code length, including prefix, suffix, length code, etc.
- ▶ Matching the first character of data

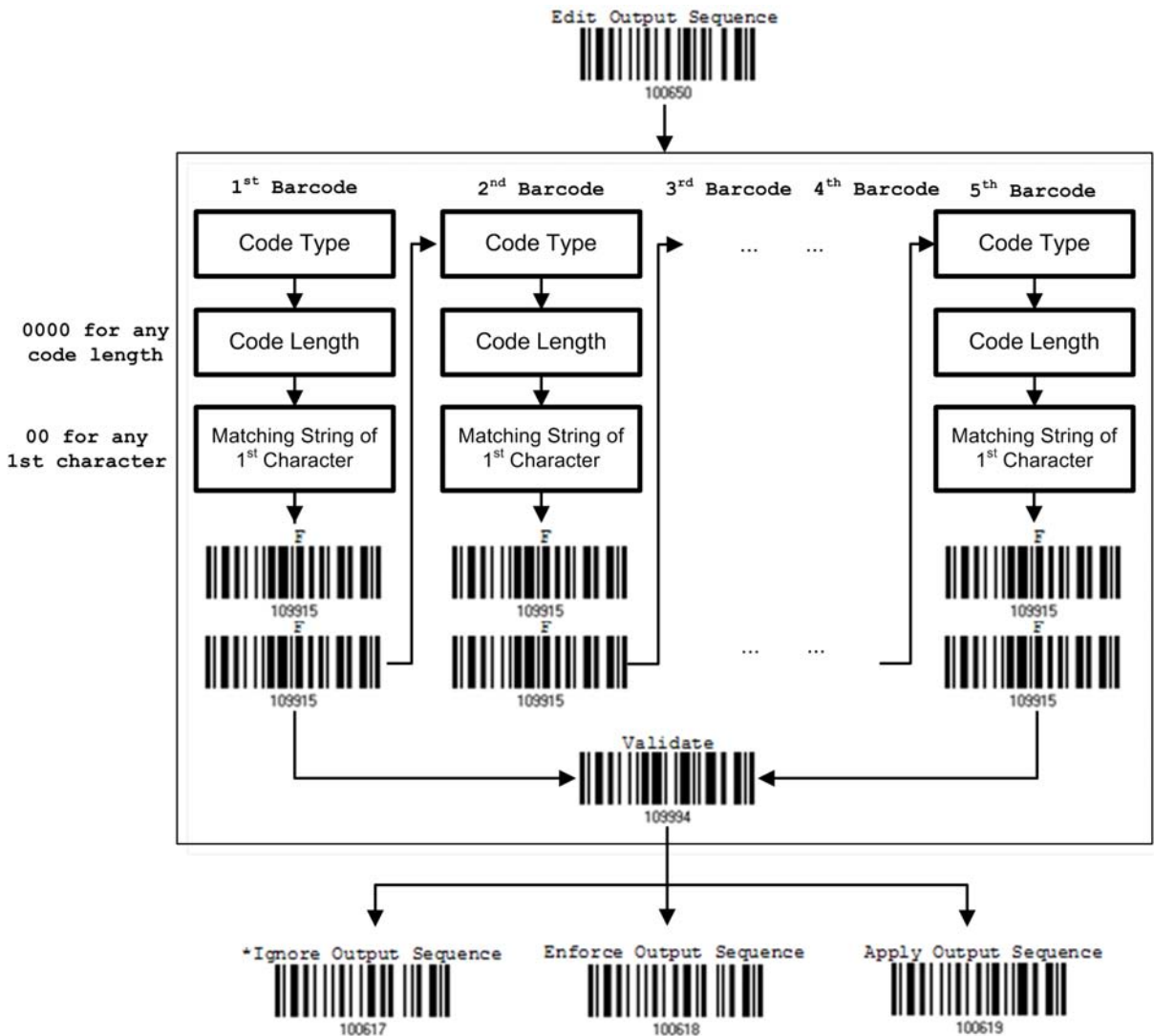

4.6.1 EDIT A CONCATENATION OF BARCODES

Edit Output Sequence



- 1) Read the label above to start editing a concatenation of barcodes.
- 2) Code Type setting – read the “[Hexadecimal Value](#)” label on page 136 for Code Type of the (first) barcode. For example, read “4” and “1” for Code 39.

Code Type	Symbology	Code Type	Symbology
41 (A)	Code 39	4F (O)	EAN-8 with Addon 5
42 (B)	Italian Pharmacode	50 (P)	EAN-13
43 (C)	French Pharmacode)	51 (Q)	EAN-13 with Addon 2
44 (D)	Industrial 25	52 (R)	EAN-13 with Addon 5
45 (E)	Interleaved 25	53 (S)	MSI
46 (F)	Matrix 25	54 (T)	Plessey
47 (G)	Codabar (NW7)	55 (U)	EAN-128
48 (H)	Code 93	56 (V)	UPC-A
49 (I)	Code 128	57 (W)	UPC-A with Addon 2
4A (J)	UPC-E0 / UPC-E1	58 (X)	UPC-A with Addon 5
4B (K)	UPC-E with Addon 2		
4C (L)	UPC-E with Addon 5	5A (Z)	Telepen
4D (M)	EAN-8	5B ([)	RSS-14
4E (N)	EAN-8 with Addon 2		

- 3) Code Length setting – read the “[Decimal Value](#)” label on page 135 for the 4-digit total length of the (first) barcode. For example, read “0065” for 65 characters or read “0000” for any length.

Note: If not reading 0000 for any length, the 4-digit length must include prefix, suffix (0x0d by default), length code, etc.

- 4) Matching Character setting – read the “[Hexadecimal Value](#)” label on page 136 for the 1st character that must be found matching in the (first) barcode. For example, read “4” and “1” for matching character “A” as the first character in the barcode or read “00” for any character.
- 5) Read twice the “F” label on page 136 (“FF”) to complete the setting of each barcode.
- 6) Read the “Validate” label to end the editing of the barcode set.



4.6.2 ACTIVATE THE CONCATENATION OF BARCODES

By default, the output sequence editing of the concatenation of barcodes is not applied.

When "Enforce Output Sequence" is enabled, all barcodes read by the scanner must meet with the criteria for the concatenation. If data is found excluded from all output sequence sets (= not meeting with the criteria), the scanner will not accept the reading, and therefore, data will not be transmitted.

When "Apply Output Sequence" is enabled, only barcodes found meeting with the criteria are counted for the concatenation. Those found not meeting with the criteria are processed normally and individually.

*Ignore Output Sequence



Enforce Output Sequence



Apply Output Sequence



Warning: When you disable the Multi-Barcode Editor later, the scan mode remains unchanged. If Laser mode is not desired, proceed to select a scan mode best suits your application.



APPLYING FORMATS FOR DATA EDITING

The scanner allows advanced data editing by applying user-configured editing formats. The whole processed data can be divided into fields by user-specified rules. These fields together with the user-configurable additional fields consist of the data actually sent to the host computer.

[Prefix Code]	[Code ID]	[Length Code]	[Data]	[Suffix Code]	Additional Field(s)
None by default	None by default	None by default	Barcode itself	0x0d by default	

IN THIS CHAPTER

5.1 Format Selection	106
5.2 Editing Format.....	108
5.3 Programming Examples	124



5.1 FORMAT SELECTION

5.1.1 ACTIVATE EDITING FORMATS

If you have already configured any editing format before, you may directly apply the editing format. If not, you must start with configuring an editing format first, and then, activate the editing format when it is desired in use.

Editing Format 1

Enable Format 1



101301

*Disable Format 1



101300

Editing Format 2

Enable Format 2



101303

*Disable Format 2



101302

Editing Format 3

Enable Format 3



101305

*Disable Format 3



101304



Editing Format 4

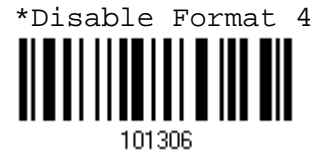

Editing Format 5



5.1.2 EXCLUSIVE DATA EDITING

By default, only barcodes found meeting with the criteria are processed by the editing formats. Those found not meeting with the criteria are processed normally.

When “Exclusive Data Editing” is enabled, all barcodes read by the scanner must be processed by the editing formats. If data is found excluded from all enabled editing formats (= not meeting with the specified criteria), the scanner will not accept the reading, and therefore, data will not be transmitted.



5.2 EDITING FORMAT

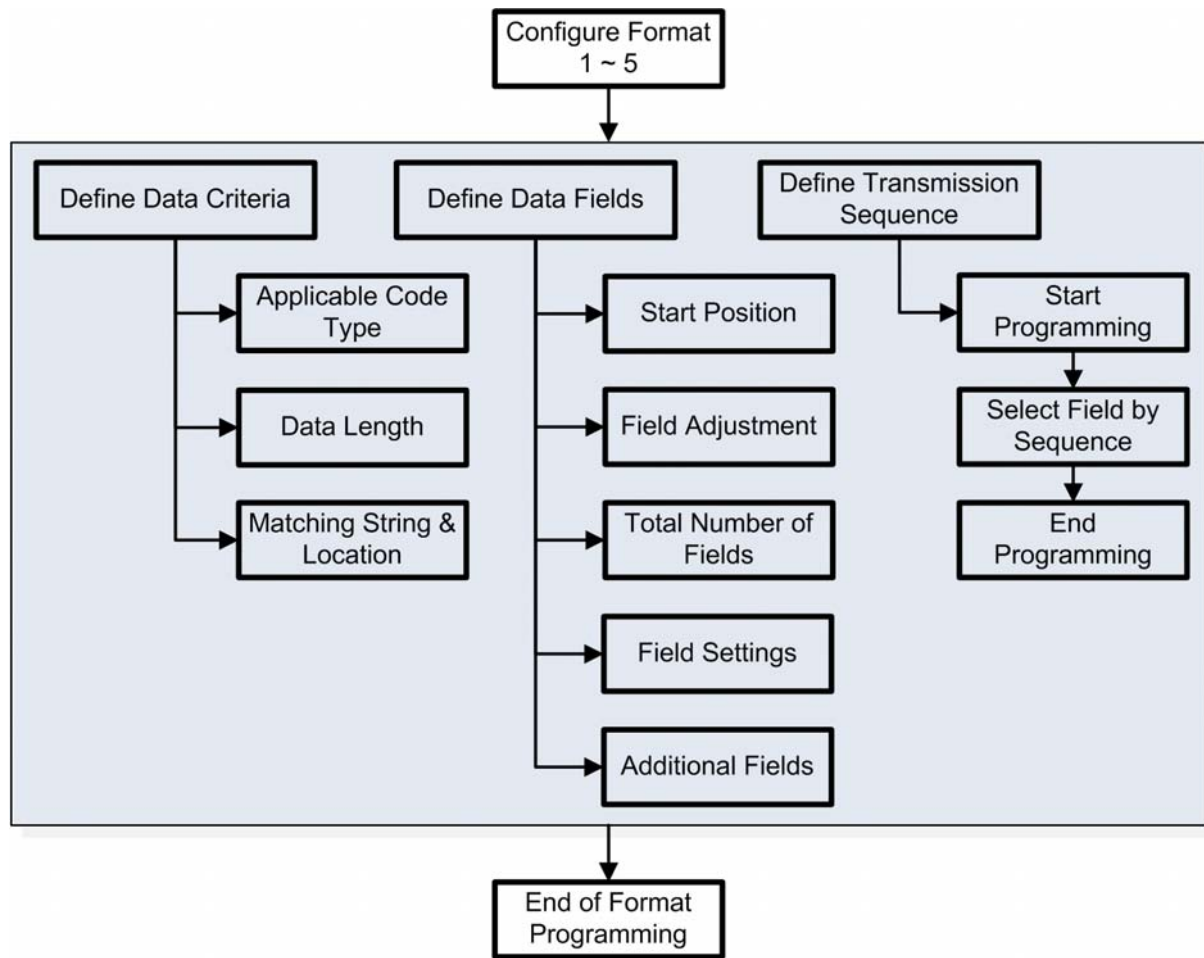

5.2.1 SELECT FORMAT TO CONFIGURE

Start Programming Format

Select one editing format (Format 1~5) and the parameters pertaining to the editing format can then be configured – applicable code type, data length, matching string & location, total number of fields, field settings (field-dividing rule), additional fields, and field transmission sequence.

- ▶ Up to five different formats can be specified.

Configure Format 1



Configure Format 2



Configure Format 3



Configure Format 4



Configure Format 5



Note: Before you complete the programming of an editing format, if you have the scanner read any label for parameters other than those pertaining to the editing format, it will automatically abort the programming process.

End Programming Format

After having configured all the desired parameters, you must have the scanner read the “End Programming Format” label, which can be located at the bottom of every even page in this chapter.

End Programming Format



5.2.2 RESTORE DEFAULT FORMAT

You may select an existing editing format and have the defaults restored. The default settings of an editing format are listed below.

Editing format	Defaults
Applicable Code Type	All
Data Length	0 (No qualification.)
Matching String	Disable
Matching String Location	None
Total Number of Fields	1
Field Setting – field-dividing rule	Not configured.
Additional Fields	None
Field Transmission Sequence	F1

Restore Default Format



109990



5.2.3 DEFINE DATA CRITERIA

Three applicable conditions can be configured to check whether the data read by the scanner can be processed by the particular editing format.

Note: Data editing cannot be performed unless the three conditions are all met.

Applicable Code Type

By default, barcodes of all the supported symbologies will be processed by any editing format, if having been configured and enabled.

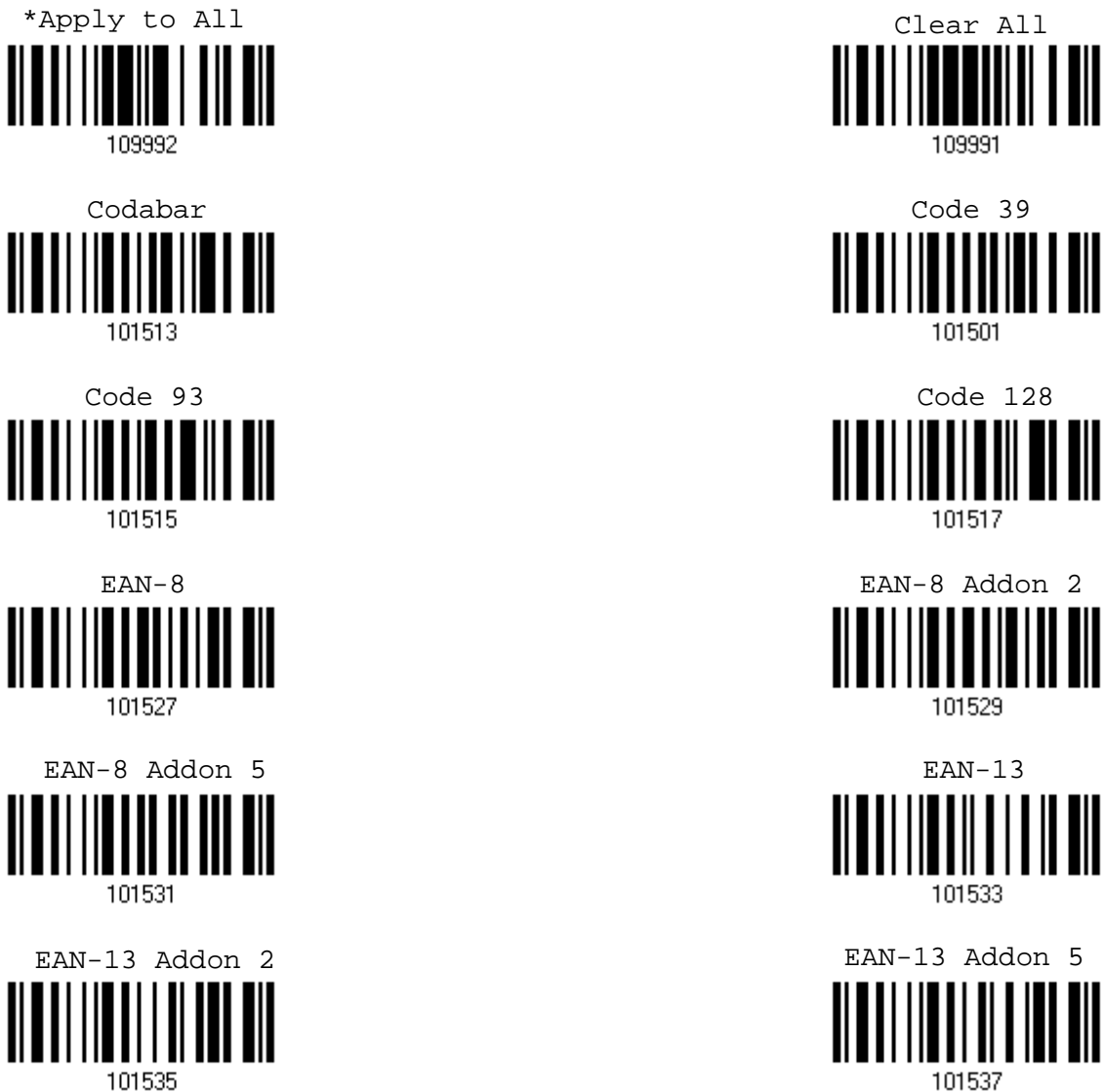

EAN-128 & RSS



101519

French Pharmacode



101505

Italian Pharmacode



101503

Industrial 25



101507

Interleaved 25



101509

Matrix 25



101511

MSI



101545

Plessey



101547

Telepen



101549

UPC-A



101539

UPC-A Addon 2



101541

UPC-A Addon 5



101543

UPC-E



101521

UPC-E Addon 2



101523

UPC-E Addon 5



101525

Data Length

By default, barcodes of any length (character count) are eligible for data editing.

- ▶ You may specify a value from 0 to 254.



- ▶ When zero is given to both, the scanner will not perform the length qualification.

1. Read the label below to specify Max. Length or Min. Length separately, and follow steps 2–3.



2. Read the "[Decimal Value](#)" label on page 135 for the desired length.
3. Read the "Validate" label on the same page to complete this setting.

Matching String & Location

By default, no matching string is specified, and therefore, it is disabled. You may enable this feature by specifying a matching string; up to four characters are allowed.

- ▶ When the Matching String Location is zero, the scanner will only check for the existence of the matching string in the barcode data.
- ▶ You may specify a value from 1 to 254 to indicate where the matching string starts in the barcode data.

1. Read the label to specify a matching string.

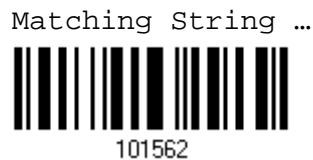

2. Read the "[Hexadecimal Value](#)" label on page 136 for the desired character string.
3. Read the "Validate" label to complete this setting.
4. Read the label to specify the location of the matching string.

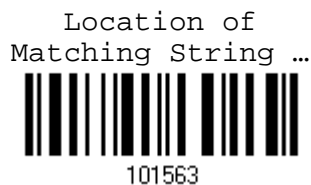

5. Read the "[Decimal Value](#)" label on page 135 for the desired location.
6. Read the "Validate" label on the same page to complete this setting.



5.2.4 DIVIDE DATA INTO FIELDS

Start Position

Data can be divided into fields in one of the following direction –

- ▶ from head (F1) to tail (F5)
- ▶ from tail (F1) to head (F5)



Field Adjustment

You may apply equal length to all fields, if necessary. It will add "Space" (0x20) to field when data is found shorter than specified.

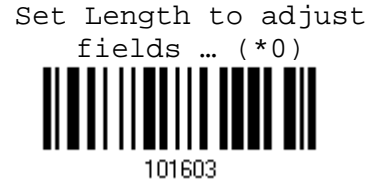

1. Read the label above to adjust field by length.
2. Read the "[Decimal Value](#)" label on page 135 for the desired field length.
3. Read the "Validate" label on the same page to complete this setting.

Total Number of Fields

Data can be divided into at most 6 fields; each of them is numbered from F1 to F6 accordingly. However, only F1~F5 can be configured.

- ▶ The total number of fields must be specified correctly. If three fields are configured for the editing format, the data characters after F3 will be assigned to F4 automatically. This feature is quite useful especially when data of variable lengths is processed by editing formats.





Note: The number of configurable fields is always one less than the total number of fields specified. The extra data characters beyond the last field configured will be automatically assigned to the next field.



5.2.5 FIELD SETTINGS

Data eligible for editing formats is divided into fields by user-specified rules – either using the field terminating string or specified field length.

<p>By Terminating String</p> <p>Specify the field terminating string. Up to two characters are allowed. The scanner will search for the occurrence of this particular string in the data.</p> <p>▶ By default, this string will be included in the field. You may discard it.</p>
<p>By Length</p> <p>Alternatively, you may simply specify the field length. The scanner will assign the next specified number of characters into the field.</p>

Field 1 Setting

Select Field Separator
to Divide Field 1 ...



1. Read the above label to divide field by a specified terminating string.
2. Read the "[Hexadecimal Value](#)" label on page 136 for the desired character string.
3. Read the "Validate" label to complete this setting.
4. Read the "Discard Separator" label if the field separator is not desired in the field.

*Include Separator



Discard Separator



If not dividing the field by a specific separator, you may divide it by a specified length.

Divide Field 1 by Length ...



1. Read the above label to divide field by length.
2. Read the "[Decimal Value](#)" label on page 135 for the desired field length.
3. Read the "Validate" label on the same page to complete this setting.



Field 2 Setting

Select Field Separator
to Divide Field 2 ...



101571

1. Read the above label to divide field by a specified terminating string.
2. Read the "[Hexadecimal Value](#)" label on page 136 for the desired character string.
3. Read the "Validate" label to complete this setting.
4. Read the "Discard Separator" label if the field separator is not desired in the field.

*Include Separator



101569

Discard Separator



101568

If not dividing the field by a specific separator, you may divide it by a specified length.

Divide Field 2 by Length ...



101570

1. Read the above label to divide field by length.
2. Read the "[Decimal Value](#)" label on page 135 for the desired field length.
3. Read the "Validate" label on the same page to complete this setting.



Field 3 Setting

Select Field Separator
to Divide Field 3 ...



1. Read the above label to divide field by a specified terminating string.
2. Read the "[Hexadecimal Value](#)" label on page 136 for the desired character string.
3. Read the "Validate" label to complete this setting.
4. Read the "Discard Separator" label if the field separator is not desired in the field.

*Include Separator



Discard Separator



If not dividing the field by a specific separator, you may divide it by a specified length.

Divide Field 3 by Length ...



1. Read the above label to divide field by length.
2. Read the "[Decimal Value](#)" label on page 135 for the desired field length.
3. Read the "Validate" label on the same page to complete this setting.



Field 4 Setting

Select Field Separator
to Divide Field 4 ...



1. Read the above label to divide field by a specified terminating string.
2. Read the "[Hexadecimal Value](#)" label on page 136 for the desired character string.
3. Read the "Validate" label to complete this setting.
4. Read the "Discard Separator" label if the field separator is not desired in the field.

*Include Separator



Discard Separator



If not dividing the field by a specific separator, you may divide it by a specified length.

Divide Field 4 by Length ...



1. Read the above label to divide field by length.
2. Read the "[Decimal Value](#)" label on page 135 for the desired field length.
3. Read the "Validate" label on the same page to complete this setting.



Field 5 Setting

Select Field Separator
to Divide Field 5 ...



101583

1. Read the above label to divide field by a specified terminating string.
2. Read the "[Hexadecimal Value](#)" label on page 136 for the desired character string.
3. Read the "Validate" label to complete this setting.
4. Read the "Discard Separator" label if the field separator is not desired in the field.

*Include Separator



101581

Discard Separator



101580

If not dividing the field by a specific separator, you may divide it by a specified length.

Divide Field 5 by Length ...



101582

1. Read the above label to divide field by length.
2. Read the "[Decimal Value](#)" label on page 135 for the desired field length.
3. Read the "Validate" label on the same page to complete this setting.



Additional Fields

Up to five additional fields can be created for each editing format; each of them is numbered from AF1 to AF5 accordingly.

1. Read the label below to specify an additional field, one at a time.
2. Read the “[Hexadecimal Value](#)” label on page 136 for the desired additional field.
3. Read the “Validate” label to complete this setting.

Additional Field 1 ...



Additional Field 2 ...



Additional Field 3 ...



Additional Field 4 ...



Additional Field 5 ...



- ▶ If “Keyboard Wedge” is configured for interface, Key Type and Key Status will then become applicable. You may decide whether or not to apply Key Status when “Normal Key” is selected for Key Type.

Key Type		Key Status
Scan Code	Up to 2 scan code values are allowed.	N/A
Normal Key	Up to 4 character strings are allowed. <ul style="list-style-type: none"> ▶ Default setting 	<ul style="list-style-type: none"> ▶ Add Shift ▶ Add Left Ctrl ▶ Add Left Alt ▶ Add Right Ctrl ▶ Add Right Alt ▶ Add Break For example, read labels for [Add Shift], [A], [Add Shift], and [B].



5.2.6 FIELD TRANSMISSION SEQUENCE

After configuring the data fields and additional fields, you must now program the transmission sequence of these fields that comprise the final data. This field transmission sequence can be assigned in any desired order and fields can be assigned multiple times as well.

Note: Up to twelve fields can be assigned.

- 1) Read the "Start" label to begin with programming the field transmission sequence.

Start (Programming) ...



101589

- 2) Program the transmission sequence by reading the desired fields as well as additional fields.

Field 1



109901

Field 2



109902

Field 3



109903

Field 4



109904

Field 5



109905

Field 6



109906

Additional Field 1



109907

Additional Field 2



109908

Additional Field 3



109909

Additional Field 4



109910

Additional Field 5



109911



3) Read the "End" label to complete this setting.



5.3 PROGRAMMING EXAMPLES

5.3.1 EXAMPLE I

Extract data from the 10th character to the 19th character...

The editing format should be configured as follows:

1. Read the "Enter Setup" label to enter the Configuration Mode.
2. Read the "Configure Format 1" label.
3. Read the "Clear All" and "Code 128" labels for applicable code type.
4. Read the "Three Fields" label.
5. Read the "Divide Field 1 by Length" label, and set length to 9.
Field 1 data starts from the 1st character to the 9th character.
6. Read the "Divide Field 2 by Length" label, and set length to 10.
Field 2 data starts from the 10th character to the 19th character.
7. Read the "Start (Programming)" label to program the transmission sequence.
8. Read the "Field 2" label.
9. Read the "End" label to complete the transmission sequence setting.
10. Read the "End Programming Format" label to complete the setting of Editing Format 1.
11. Read the "Enable Format 1" label to apply Editing Format 1 to Code 128.
12. Read the "Update" label to exit the Configuration Mode.



5.3.2 EXAMPLE II

Extract the date code, item number, and quantity information from barcodes.

Data in a barcode is encoded like this:

- ▶ From the 1st character to the 6th character is the date code.
- ▶ From the 7th character to the dash '-' character is the item number.
- ▶ After the dash '-' character is the quantity information.

Data will be transmitted like this:

- ▶ The item number goes first, then a TAB character, followed by the date code, then another TAB character, and finally the quantity information.

The editing format should be configured as follows:

1. Read the "Enter Setup" label to enter the Configuration Mode.
2. Read the "Configure Format 2" label.
3. Read the "Three Fields" label.
4. Read the "Divide Field 1 by Length" label, and set length to 6.
Field 1 data starts from the 1st character to the 6th character.
5. Read the "Select Field Separator to Divide Field 2" label, and use a dash '-' character.
Field 2 data starts from the 7th character until the dash '-' character is met.
6. Read the "Additional Field 1" label, and use a tab character for the field.
7. Read the "Start (Programming)" label to program the transmission sequence.
8. Read the "Field 2", "Additional Field 1", "Field 1", "Additional Field 1", "Field 3" labels.
9. Read the "End" label to complete the transmission sequence (F2 A1 F1 A1 F3) setting.
10. Read the "End Programming Format" label to complete the setting of Editing Format 1.
11. Read the "Enable Format 2" label to apply Editing Format 2 to all code types.
12. Read the "Update" label to exit the Configuration Mode.





SPECIFICATIONS

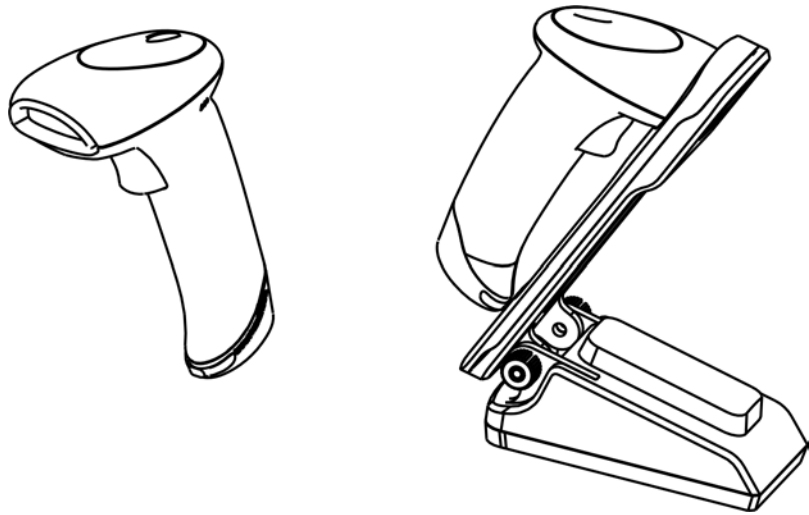

Optical Characteristics		1500
Scan Engine		Non-contact type
Optical Sensor		CCD, 2500 pixels
Light Source		Visible red LED
Wavelength		625 nm
Physical Characteristics		
Color		Black
Switch		Tactile switch
Interface Options		Keyboard Wedge, RS-232, Wand Emulation
Weight		Approx. 145 g
Electrical Characteristics		
Voltage		+ 5V ± 5%
Power Consumption	Standby	30 mA
	Scanning	170 mA
	Maximum	250 mA



Environmental Characteristics

Temperature	Operating	0 °C to 50 °C
	Storage	-20 °C to 60 °C
Humidity (Non-condensing)	Operating	10% to 90%
	Storage	5% to 95%
Impact Resistance (Multiple drops onto concrete)		1.5 m
Electrostatic Discharge		± 15 kV air discharge, ± 8 kV direct discharge
EMC Regulation		FCC, CE, C-Tick, MIC, BSMI

Programming Support

Configuration via Setup Labels	Use setup labels or host serial commands.
Software	Windows-based ScanMaster
Firmware upgradeable	Download firmware updates via the download utility.

Accessories (√ means “supported”)

USB HID Cable (307)	√
USB Virtual COM Cable (308)	√
IBM 4683/4694 Cable (346)	√
Auto-Sense Stand	√
RS-232 Cable	√
Keyboard Wedge Cable	√
Wand Emulation Cable	√



UPGRADING FIRMWARE

- 1) Use the RS-232 cable to connect the scanner to the serial port of PC and join the power adaptor to the RS-232 connector.
- 2) Read the following labels in sequence for the scanner to enter the download mode.
The scanner will respond with beeps to indicate it is ready for downloading.



- 3) Run the download utility "ProLoad.exe" or "Download.exe" on your computer.
(Download.exe requires version 2.3 or later!)
Open the firmware update "*.shx", and select the correct COM port.
 - ▶ Baud rate — 115,200 bps
 - ▶ Data bit — 8
 - ▶ Parity — None
 - ▶ Flow control — None
- 4) The scanner will automatically restart itself when upgrading firmware is completed successfully.





HOST SERIAL COMMANDS

SERIAL COMMANDS

D

Purpose To disable the scanner.
Remarks "D"

E

Purpose To enable the scanner.
Remarks "E"

#@ nnnnnn <CR>

Purpose To configure the scanner.
Remarks nnnnnn – the six digits of command parameters. For example, "109952" is to list the current Code ID settings.



"0x23" + "0x40" + "0x31" + "0x30" + "0x39" + "0x39" + "0x35" + "0x32" + "0x0d"

#@ ----<CR>

Purpose To halt the scanner.
Remarks "0x23" + "0x40" + "0x2d" + "0x2d" + "0x2d" + "0x2d" + "0x0d"

#@<CR>

Purpose To resume operation.
Remarks "0x23" + "0x40" + "0x2e" + "0x2e" + "0x2e" + "0x2e" + "0x0d"

#@////<CR>

Purpose To respond with a beep.
Remarks "0x23" + "0x40" + "0x2f" + "0x2f" + "0x2f" + "0x2f" + "0x0d"

#@TRIGOFF<CR>

Purpose Disable software trigger
Remarks "0x23" + "0x40" + "0x54" + "0x52" + "0x49" + "0x47" + "0x4f" + "0x46" + "0x46"
+ "0x0d"



#@TRIGON<CR>

Purpose Enable software trigger

Remarks "0x23" + "0x40" + "0x54" + "0x52" + "0x49" + "0x47" + "0x4f" + "0x4e" + "0x0d"

EXAMPLE

Send the serial commands via RS-232 interface. For example, run HyperTerminal on the host computer.

- ▶ For the scanner to stop immediately –
D
- ▶ For the scanner to resume to work –
E
- ▶ For the scanner to change the beeper to medium volume and beep –
#@101011<CR>
#@////<CR>
- ▶ For the scanner to change the beeper to minimal volume and beep –
#@101010<CR>
#@////<CR>
- ▶ For the scanner to change the beeper frequency to 8 kHz (for Good Read Beep only) and beep –
#@101001<CR>
#@////<CR>
- ▶ For the scanner to change the beeper length to longest (for Good Read Beep only) and beep –
#@101008<CR>
#@////<CR>



KEYBOARD WEDGE TABLE

	0	1	2	3	4	5	6	7	8
0		F2	SP	0	@	P	`	p	⓪
1	INS	F3	!	1	A	Q	a	q	①
2	DLT	F4	"	2	B	R	b	r	②
3	Home	F5	#	3	C	S	c	s	③
4	End	F6	\$	4	D	T	d	t	④
5	Up	F7	%	5	E	U	e	u	⑤
6	Down	F8	&	6	F	V	f	v	⑥
7	Left	F9	'	7	G	W	g	w	⑦
8	BS	F10	(8	H	X	h	x	⑧
9	HT	F11)	9	I	Y	i	y	⑨
A	LF	F12	*	:	J	Z	j	z	
B	Right	ESC	+	;	K	[k	{	
C	PgUp	Exec	,	<	L	\	l		
D	CR	CR*	-	=	M]	m	}	
E	PgDn		.	>	N	^	n	~	
F	F1		/	?	O	_	o	Dly	ENTER*

Note: (1) ⓪~⑨: Digits of numeric keypad.
 (2) CR*/Send/ENTER*: ENTER key on the numeric keypad.

KEY TYPE

If "Keyboard Wedge" is configured for interface, Key Type and Key Status will then become applicable.

*Normal



109926





KEY STATUS

Decide whether or not to change key status when “Normal Key” is selected for Key Type.

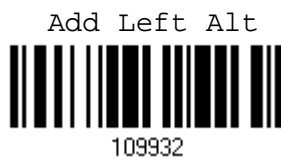

USER-DEFINED SCAN CODE

1) Read the “Set Scan Code” label to define new scan code.



2) Read the “[Hexadecimal Value](#)” label on page 136 for the desired character string.

3) Read the “Validate” label to complete this setting.

4) Read the “Confirm” label to confirm the action.



NUMERAL SYSTEMS

DECIMAL SYSTEM

Decimal



Validate the Values



HEXADECIMAL SYSTEM

Hexadecimal



Validate the Values



ASCII TABLE

	0	1	2	3	4	5	6	7	
0		DLE	SP	0	@	P	`	p	
1	SOH	DC1	!	1	A	Q	a	q	
2	STX	DC2	"	2	B	R	b	r	
3	ETX	DC3	#	3	C	S	c	s	
4	EOT	DC4	\$	4	D	T	d	t	
5	ENQ	NAK	%	5	E	U	e	u	
6	ACK	SYN	&	6	F	V	f	v	
7	BEL	ETB	'	7	G	W	g	w	
8	BS	CAN	(8	H	X	h	x	
9	HT	EM)	9	I	Y	i	y	
A	LF	SUB	*	:	J	Z	j	z	
B	VT	ESC	+	;	K	[k	{	
C	FF	FS	,	<	L	\	l		
D	CR	GS	-	=	M]	m	}	
E	SO	RS	.	>	N	^	n	~	
F	SI	US	/	?	O	_	o	DEL	

Update



Abort



